

**ASSEMBLY INSTRUCTIONS**  
*FKF 200 / 240 / 270 ROOF MOUNTED*

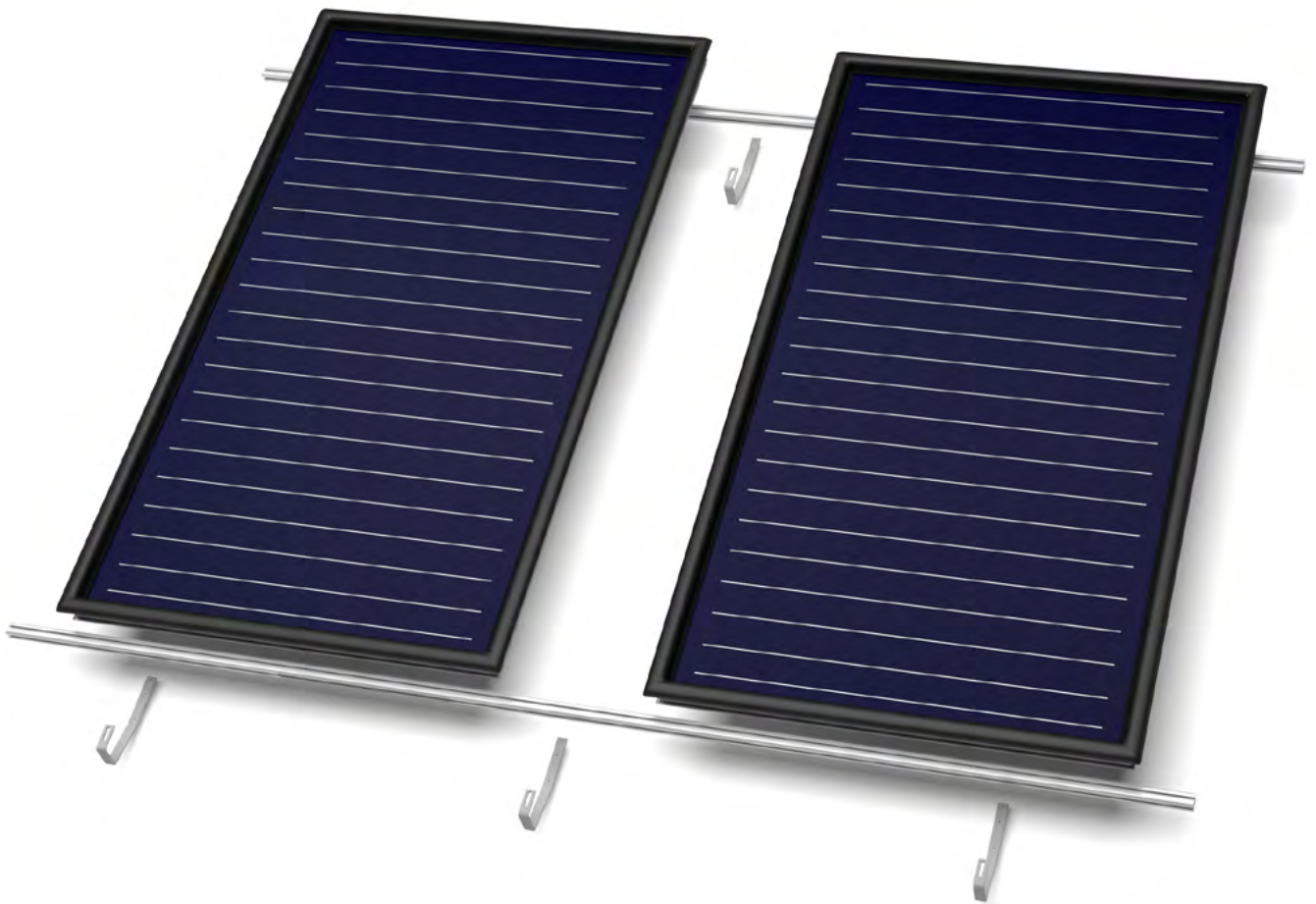

**SOLARE KOMPETENZ**  
*AUS SACHSEN*

# Table of contents

Content	Page
<b>Safety regulations, instruction and guidelines</b>	<b>3</b>
<b>Tools</b>	<b>5</b>
<b>Product description</b>	<b>6</b>
<b>Collector field dimensions</b>	<b>8</b>
<b>Hydraulic connections</b>	<b>10</b>
<b>Spacing multi-row collector fields</b>	<b>11</b>
<b>Roof-mounted installation on roof-tiles</b>	<b>12</b>
<b>Assembly of the roof-tile clamps</b>	<b>13</b>
<b>Assembly of the roof-tile clamps with lead cloth</b>	<b>15</b>
<b>Assembly of the roof-tile clamps for plain tile</b>	<b>17</b>
<b>Assembly of the plain tile clamps with lead</b>	<b>18</b>
<b>Assembly roof-tile clamps for corrugated sheet</b>	<b>20</b>
<b>Assembly of the fastening profiles</b>	<b>21</b>
<b>Assembly preparation - sequence</b>	<b>25</b>
<b>Assembly of the intermediate plates/ multi-row collector fields</b>	<b>27</b>
<b>Assembly of the solar collectors</b>	<b>29</b>
<b>Assembly of the probe</b>	<b>32</b>
<b>Collector connections</b>	<b>33</b>
<b>Hydraulic connection with manifold</b>	<b>34</b>
<b>Overview hydraulic connections SLS / accessories</b>	<b>35</b>
<b>Overview hydraulic connections / accessories aluminium</b>	<b>36</b>
<b>Assembly intermediate plates</b>	<b>37</b>
<b>Assembly of the roof implementation set</b>	<b>38</b>
<b>Assembly of the connecting pipe</b>	<b>40</b>
<b>SnapCover</b>	<b>41</b>
<b>SnapCover - assembly sequence</b>	<b>44</b>
<b>Pipe dimension of the connecting pipe</b>	<b>45</b>
<b>Initial operation</b>	<b>47</b>
<b>Appendix</b>	<b>51</b>

Please read these instructions carefully before beginning the assembly.

Observe the warnings indicated by this sign:



They warn against dangers or erroneous actions. A disregard of the advices and regulations mentioned in the assembly instruction may result in the invalidation of the warranty claim.

The collectors FKF 200, FKF 240, FKF 270 are monitored according to the CEN-Keymark programme rules Solarthermal Products and are certified with the registration numbers 011-7S1913/1914/1915.

The copyright of this instruction incl. graphical material remains property of the STI GmbH. The instruction can only be duplicated completely or in parts with written authorisation of the STI GmbH. Subject to technical changes and misprints.

The collectors of the FKF series series are marked with the environmental label RAL-UZ-73 for solar collectors („Blauer Engel“). The STI GmbH is obliged to take back the products which are marked with the environmental label RAL-UZ-73 for solar collectors and to consign them for recycling.

# Safety regulations, instruction and guidelines

The standards and guidelines applied at the installation location of the collectors have to be considered in the latest release.

## Engineer standards and guidelines

- VBG 4 Unfallverhütungsvorschriften Elektrische Anlagen und Betriebsmittel
  - VBG 37 Unfallverhütungsvorschrift Bauarbeiten
  - VBG 74 Leitern und Tritte
  - ZVDH, Regelwerk
  - LBO's Landesbauordnungen der Bundesländer
  - DIN 18299 Allgemeine Regelung für Bauarbeiten jeder Art
  - DIN 18334 Zimmer- und Holzbauarbeiten
  - DIN EN 12828:2013-04 Heizungsanlagen in Gebäuden
  - DIN 18338 Dachdeckungs- und Dachabdichtungsarbeiten
  - DIN 18339 Klempnerarbeiten
  - DIN 18351 Fassadenarbeiten
  - DIN 18360 Metallbauarbeiten, Schlosserarbeiten
  - DIN 18381 Gas-, Wasser- und Abwasserinstallationsanlagen
  - DIN 18451 Gerüstarbeiten
  - DIN DIN 1055 – Einwirkungen auf Tragwerke - Teil 2: Bodenkenngrößen
  - DIN EN 1991 Einwirkungen auf Tragwerke Teil 1-7
  - DIN 4708 Teil 3 Zentrale Brauchwassererwärmungsanlagen
  - DIN 4102 Brandverhalten von Baustoffen und Bauteilen
  - DIN 4109 Schallschutz im Hochbau
  - DIN EN 516 Einrichtungen zum Betreten des Daches
  - EN 517 Sicherheitsdachhaken
  - DIN 4753 Teil 1 Wassererwärmer und Wassererwärmungsanlagen für Trink- und Betriebswasser; Anforderungen, Kennzeichnung, Ausrüstung und Prüfung
- Teil 2: Sonnenheizungsanlagen mit organischen Wärmeträgern; Anforderungen an die sicherheitstechnische Ausrüstung
- DIN VDE 0100-510 Errichten von Starkstromanlagen mit Nennspannungen bis 1000 V; Allgemeine Bestimmungen
  - DIN VDE 0100-737 Errichten von Niederspannungsanlagen - Feuchte und nasse Bereiche und Räume und Anlagen im Freien
  - DIN EN 62305-1; VDE 0185-305 Blitzschutz
  - DIN VDE 0105-100 Betrieb von elektrischen Anlagen
  - DIN EN 12976: Thermische Solaranlagen und ihre Bauteile (vorgefertigte Anlagen)
  - DIN EN 12977: Thermische Solaranlagen und ihre Bauteile (kundenspezifisch gefertigte Anlagen)
  - DIN 1988: Technische Regeln für Trinkwasser-Installation



## Notes prior to the installation start

The installation and initial operation must be carried out by an expert who is responsible for the correct installation and operation.

Before installing and putting the collectors into service, please inform about the local engineer standards and regulations.

Components of the collectors can reach temperatures of more than 200 °C, there is a danger of burning and scalding!

Furthermore it has to be checked whether there are any load sources in the area of the collector field which may produce chemically aggressive mediums. In condensate dissolved acids and bases may cause permanent damage to the collector components.

Throughout the installation of a solar collector you directly intervene into an existing roof cladding. Different roof coverings such as tile, shingles or slate require additional measures (e. g. sarkings) as a security against the ingress of moisture due to rain or snow - especially in case of extended and occupied top floors or in case of insufficient roof pitches (concerning the covering).



## Information on foliation



If the collectors are mounted with foil, this foil must be removed from the collectors at the latest 3 months after delivery. After that, residue-free removal can no longer be guaranteed.

The date of the delivery note counts.

# Safety regulation, instructions and guidelines

The substructure as well as its connections to the building have to be checked on site according to the local regulations.

The collectors have to be mounted in an angle of at least 20° to max. 70°.

The recommended heat transfer medium is a mixture of glycol and water, e. g. Tyfocor L or similar. The collectors must never be operated or tested with water under pressure.

To protect the system from overheating during standstill and accelerated glycole-ageing, a self-draining system (e. g. STI Drain Master or SolBox) is recommended.

It is necessary to pay attention that the back flow temperature is never lower than the ambient temperature. If necessary, take appropriate action (e. g. increase back flow temperature to at least 30 °C).

To avoid a possible forming of condensate in the collector, the installation has to be taken into operation hydraulically within two weeks after termination of the assembly. At low temperatures, the forming of condensate may cause frost damages in the collector.

## Lightning protection

Please note country-specific legislation!

Throughout the installation of metal fastening systems, a check has to be done by an authorized qualified electrician.

The metallic pipes of the solar circle are connected with the earth circuit connector via a copper pipe of at least 16 mm<sup>2</sup>.

Please ensure sufficient ventilation for each assembly method. Do not close the ventilation openings. Especially in case of a roof-integrated assembly, the ventilation of the collector is definitely necessary. Appropriate ventilation hoods are available from the supplier. Please pay attention to the regulations of the ZVDH (Germany), SVDW (Switzerland) as well as different local regulations concerning the ventilation. If necessary, consult an expert.

## Responsibilities

The constructor of the installation is responsible for the integration of the installation according to the regulations and for the compliance with safety regulations.

The operator of the installation is responsible for its operation according to the regulations and for the consultation of experts in case of problems.

This instruction is not subject to a service of modification. It does not absolve the manufacturer and operator of the installation from his responsibilities to install and operate all parts of the installation according to utmost professional knowledge. The manufacturer of the installation is responsible for observing and keeping all appropriate regulations and instructions.

## Statics

Before beginning the assembly it is vital to test the roof or substructure on site for sufficient load-carrying capacity.

Please pay increased attention to the possible durability of the screw fittings to fasten the collectors as well as to the quality of the substructure.

According to DIN EN 1991 or rather to the local engineer standards, it is necessary to check the whole system construction on site, especially in snowy regions (note: 1m<sup>3</sup> powder snow ~ 60 kg / 1 m<sup>3</sup> wet snow ~ 200 kg) as well as in regions with high wind speed. Before starting the assembly, all aspects that may lead to incorrect load of the whole construction have to be considered!

Install the collectors in such a way that a backlog of snow (e. g. due to snow guards or other obstacles) is not possible.

In case of correct assembly, snow loads (pressure loads) up to 2 kN/m<sup>2</sup> and wind loads (suction loads) up to 1,1 kN/m<sup>2</sup> acting on the collector are permitted.

## Transport and stocking

Never store the delivered collectors unprotected at the building site.

Always stock the collectors upright and leaning against a solid surface.

If the collectors are stored outside they must be stood upright with the backside leaned against the wall (glass forwards). The collectors must be covered so that neither dust nor water can enter the collectors.

If it is not possible to stand the collectors upright (e.g. flat roof), the collectors must be stacked with 2 square timbers between each collector.

Never lay down the collectors onto a rough surface with overhanging pieces like stones, timbers etc.

The rigidity of the collectors is limited. During transport to the building site always ensure a torsion-free transport. In case of an elevated intermediate storage make sure that the collectors are protected against sliding down.



# Tools

The following tools are needed for the assembly of the collectors:



Cordless screwdriver  
Bit TX 20, AW 20 \*



Angle grinder  
diamond/stone



Chalk box



\*Allen screw SW 4 \*



Drill 8,5 mm, 14 mm



Saw



Ratchet, lengthening and 13 mm  
socket wrench, combination wrench  
13 mm



Securing devices,  
protective equipment



Roof ladder

\* included in the STI tool kit 2014 1910101



# Product description



## Solar collector FKF

The solar thermal collector FKF uses the radiant energy of the sun to heat a heat transfer medium. This glycol-water mixture gives off the heat to a storage via a heat exchanger. The obtained energy can be used for water heating and heating support.

## Sectional model

- 1 Aluminium frame
- 2 Insulation
- 3 Insulation
- 4 Stucco back panel
- 5 Highly selective mono-material copper absorber
- 6 Glass
- 7 EPDM sealing
- 8 EPDM sealing

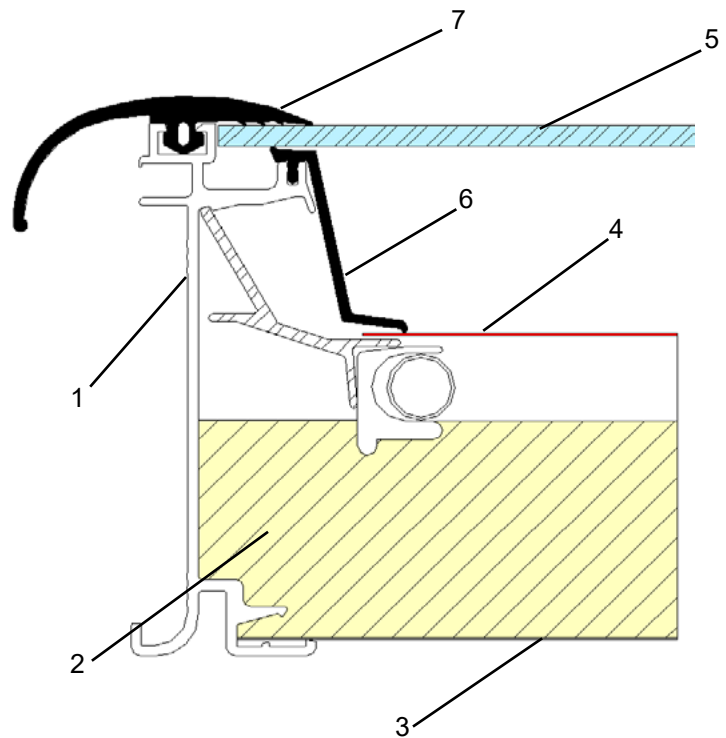

# Product description

## Specifications

The FKF collector has a pure copper absorber with meander shaped tubes as well as integrated manifolds. The hydraulic system enables to connect 15 collectors in one series and up to six collectors on one side. In one collector field up to 45 collectors can be connected in three rows.

Modell FKF	200 V	240 V	270 V	200 H	240 H	270 H
Gross surface	2,10 m <sup>2</sup>	2,52 m <sup>2</sup>	2,85 m <sup>2</sup>	2,10 m <sup>2</sup>	2,52 m <sup>2</sup>	2,85 m <sup>2</sup>
Apertur area	1,83 m <sup>2</sup>	2,22 m <sup>2</sup>	2,52 m <sup>2</sup>	1,83 m <sup>2</sup>	2,22 m <sup>2</sup>	2,52 m <sup>2</sup>
Length	1.746 mm	2.100 mm	2.373 mm	1.200 mm	1.200 mm	1.200 mm
Width	1.200 mm	1.200 mm	1.200 mm	1.746 mm	2.100 mm	2.373 mm
Height	85 mm	85 mm	85 mm	85 mm	85 mm	85 mm
Test pressure	10 bar	10 bar	10 bar	10 bar	10 bar	10 bar
Operating pressure	6 bar	6 bar	6 bar	6 bar	6 bar	6 bar
Fluid volume Co-Co / Al-Co	2,1 l	2,2 l	2,4 l	2,7 l	2,7 l	3,1 l
Fluid volume Al-Al	1,8 l	1,9 l	2,1 l	2,4 l	2,4 l	2,7 l
Flow per m <sup>2</sup>	15 - 40 l/h	15 - 40 l/h	15 - 40 l/h	15 - 40 l/h	15 - 40 l/h	15 - 40 l/h
Weight Co-Co	37 kg	39 kg	42 kg	37 kg	39 kg	42 kg
Weight Al-Co	35 kg	37 kg	40 kg	35 kg	37 kg	40 kg
Weight Al-Al	34 kg	35 kg	38 kg	34 kg	35 kg	38 kg
Loss of pressure (T=20°C / 30l/h)	6.141 Pa	8.522 Pa	11.217 Pa	4.082 Pa	6.297 Pa	7.988 Pa

## Hydraulic system of the absorber

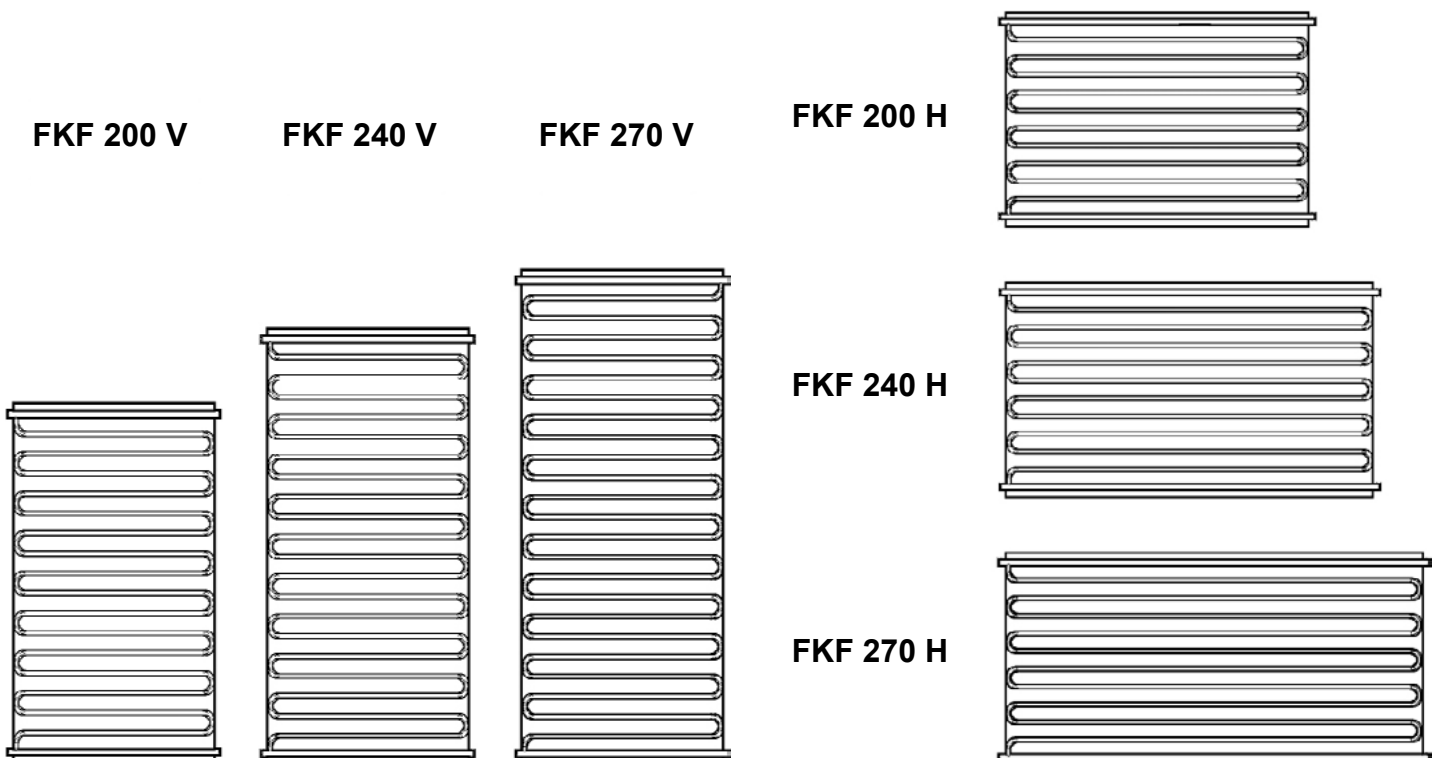

# Collector field dimensions

## Vertical section across a collector field

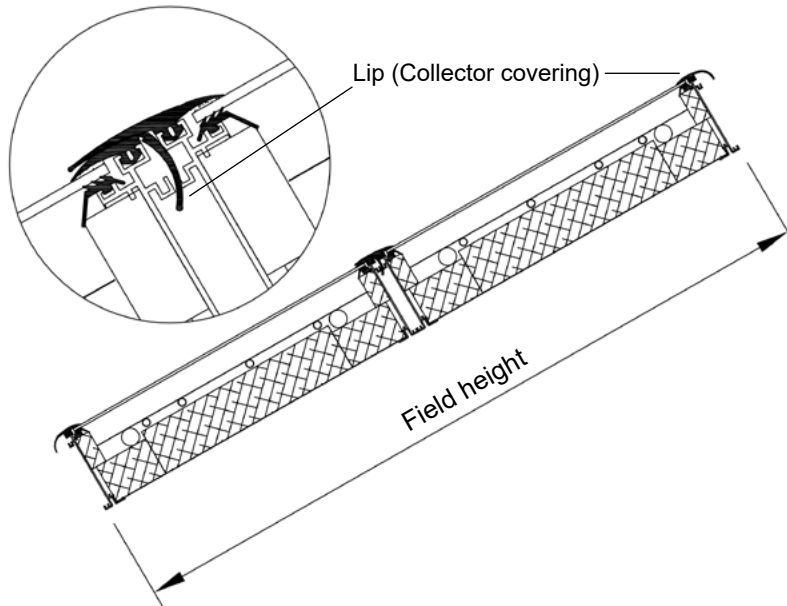

In case of multi-row installations, the collectors will always be mounted on joint on top of each other. The lip (collector covering) of the upper collector has to be put onto the lower collector. The lip (collector covering) of the lower collector has to be clamped into the joint area to ensure an optimum water flow.

## Horizontal section across a collector field

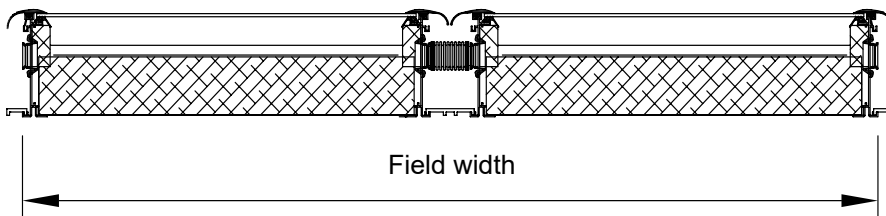

Collectors which are mounted side by side in one row are always connected by means of stainless steel expansion joints on the manifolds (see photo).

It is possible to assemble metal sheets between the collectors to achieve a homogeneous appearance of the installation. The distance metal sheets are assembled exclusively for optical aspects and do not have any influence on the installation. Therefore the distance metal sheets can be ordered optionally and are not necessarily included in delivery.



1300002 Collector connection set hydraulic





# Collector field dimensions

## Collector type

<b>200 V</b>	Number of collectors	1	2	3	4	5	6	7	8	each additional collector
	Field width in mm	1.167	2.387	3.607	4.827	6.047	7.267	8.487	9.707	+ 1.220
	Number of rows	1	2	3	4	5	6	7	8	
	Field height in mm	1.713	3.426	5.139	6.852	8.565	10.278	11.991	13.704	+ 1.713

<b>200 H</b>	Number of collectors	1	2	3	4	5	6	7	8	each additional collector
	Field width in mm	1.713	3.479	5.245	7.011	8.777	10.543	12.309	14.075	+ 1.766
	Number of rows	1	2	3	4	5	6	7	8	
	Field height in mm	1.167	2.334	3.501	4.668	5.835	7.002	8.169	9.336	+ 1.167

<b>240 V</b>	Number of collectors	1	2	3	4	5	6	7	8	each additional collector
	Field width in mm	1.167	2.387	3.607	4.827	6.047	7.267	8.487	9.707	+ 1.220
	Number of rows	1	2	3	4	5	6	7	8	
	Field height in mm	2.067	4.134	6.201	8.268	10.335	12.402	14.469	16.536	+ 2.067

<b>240 H</b>	Number of collectors	1	2	3	4	5	6	7	8	each additional collector
	Field width in mm	2.067	4.187	6.307	8.427	10.547	12.667	14.787	16.907	+ 2.120
	Number of rows	1	2	3	4	5	6	7	8	
	Field height in mm	1.167	2.334	3.501	4.668	5.835	7.002	8.169	9.336	+ 1.167

<b>270 V</b>	Number of collectors	1	2	3	4	5	6	7	8	each additional collector
	Field width in mm	1.167	2.387	3.607	4.827	6.047	7.267	8.487	9.707	+ 1.220
	Number of rows	1	2	3	4	5	6	7	8	
	Field height in mm	2.340	4.680	7.020	9.360	11.700	14.040	16.380	18.720	+ 2.340

<b>270 H</b>	Number of collectors	1	2	3	4	5	6	7	8	each additional collector
	Field width in mm	2.340	4.733	7.126	9.519	11.912	14.305	16.698	19.091	+ 2.393
	Number of rows	1	2	3	4	5	6	7	8	
	Field height in mm	1.167	2.334	3.501	4.668	5.835	7.002	8.169	9.336	+ 1.167

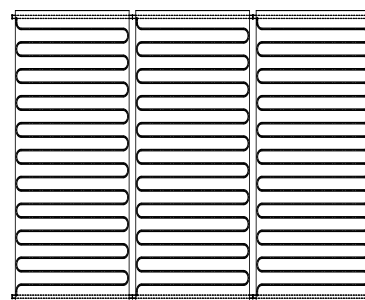

### Example

Six collectors FKF 240 H in two rows

Field width: **6.307 mm**  
Field height: **2.334 mm**

### Example

Three collectors FKF 240 V in one row

Field width: **3.607 mm**  
Field height: **2.067 mm**

# Hydraulic connections

## Temperature sensor

Each collector has a sleeve for inserting a temperature sensor. The sleeve is directly connected with the absorber. If the collectors are installed correctly, the sleeve is always located on the top of the collector on the left. The temperature sensor can be inserted in any collector. Please pay attention to the maximum insertion depth of 4 cm and secure the sensor against slipping out. Due to the measuring point on the absorber, the temperature measured by the sensor may differ from the fluid temperature.

## Installations with one up to six collectors in one row

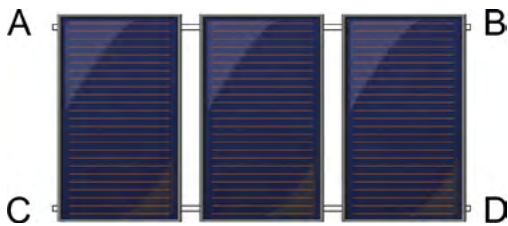

Connection F red A or B  
Connection BF blue C or D

Close unused connections with caps.



## Installations with seven up to 15 collectors in one row

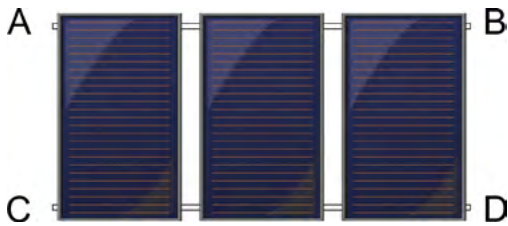

Connection bottom left / top right  
 $BF = C / F = B$   
Connection top left / bottom right  
 $BF = D / F = A$

Close unused connections with caps.

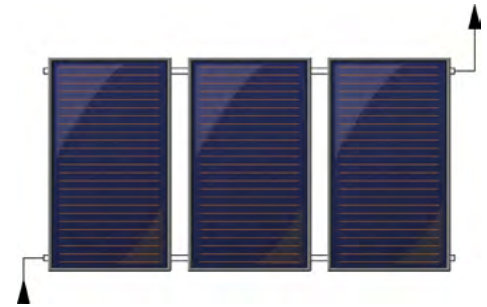

## Multi-row installations

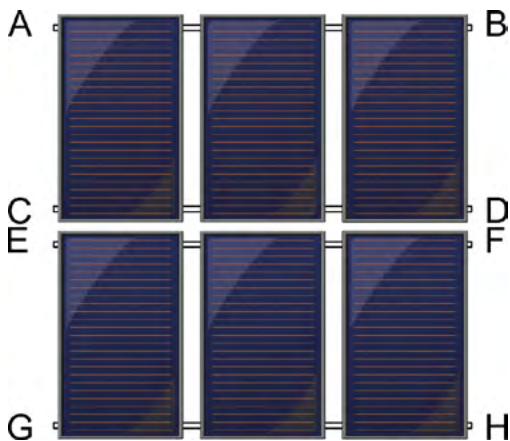

Connection F A + E / BF H + D  
Connection F B + F / BF G + C

Close unused connections with caps.

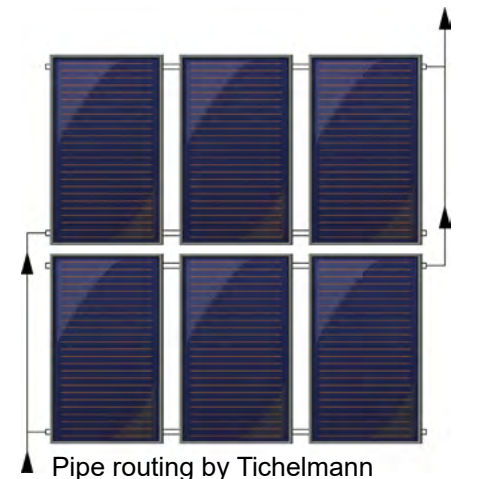

Pipe routing by Tichelmann

In case of multi-row installations as well as installations which include the STI Drain Back System, the connection pipe must always be connected with the diagonal line to the external manifold (Tichelmann), e. g. bottom left and top right.

**F = Flow (from the collector to the storage) red grommet**  
**BF = Backflow (from the storage to the collector) blue grommet**  
**In case of installing an air eliminator, install it at the opposite end of the top flow connection!**



# Spacing multi-row collector fields

## Distance measures fastening hooks

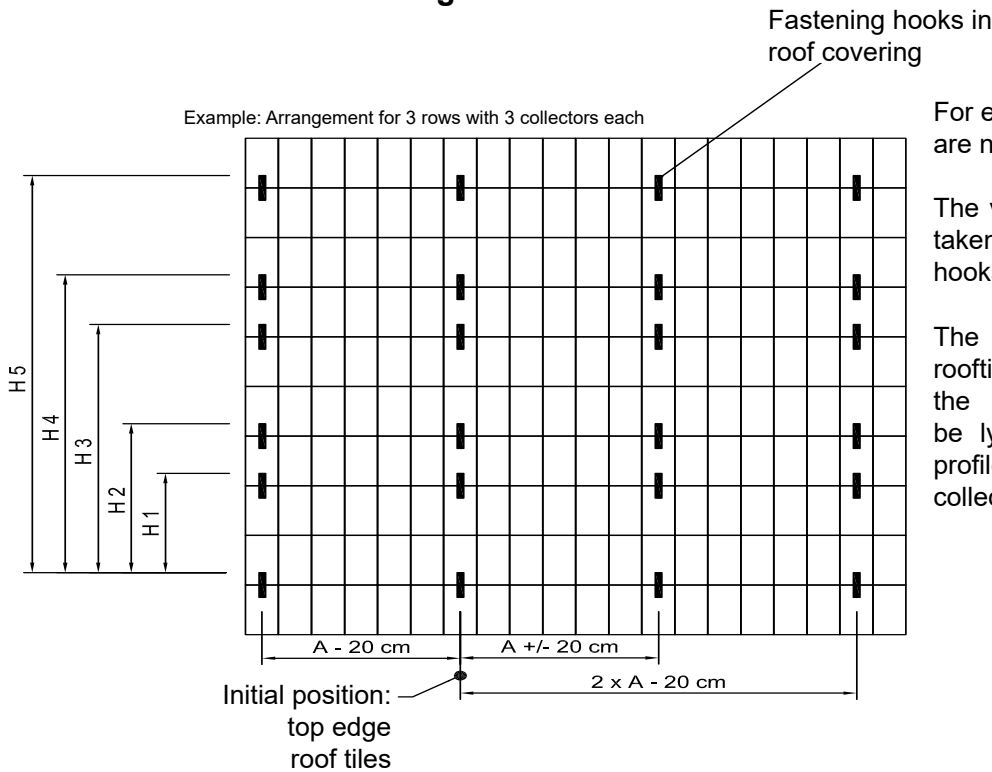

For each collector row two fastening hooks are needed.

The vertical measures H1 to Hn are each taken on the top edge of the fastening hooks.

The measures for the installation of the rooftile brackets are obligatory. Otherwise, the hydraulic collector connection may be lying at the height of the mounting profile which makes it difficult to fasten the collectors on the profile.



Horizontal measure	FKF 200 H	FKF 200 V	FKF 240 H	FKF 240 V	FKF 270 H	FKF 270 V
Measure A	171,3 cm	122 cm	212 cm	122 cm	239.3 cm	122 cm

Vertical measure Tolerance	FKF 200 H +/- 10 cm	FKF 200 V +/- 10 cm	FKF 240 H +/- 10 cm	FKF 240 V +/- 10 cm	FKF 270 H +/- 10 cm	FKF 270 V +/- 10 cm
Measure H1	97 cm	151 cm	97 cm	187 cm	97 cm	214 cm
Measure H2	137 cm	191 cm	137 cm	227 cm	137 cm	254 cm
Measure H3	214 cm	322 cm	214 cm	394 cm	214 cm	448 cm
Measure H4	254 cm	362 cm	254 cm	434 cm	254 cm	488 cm
Measure H5	331 cm	493 cm	331 cm	601 cm	331 cm	682 cm
x	117 cm	171 cm	117 cm	207 cm	117 cm	234 cm

The next series is given by:

$$H_n = H_n - 2 + x$$

whereby n is the number of the row of roof-tiles to be calculated.

Example FKF 240 H

$$H_6 = H_6 - 2 + x$$

$$H_6 = H_4 + x \quad (\text{Height H4 see table})$$

$$H_6 = 254 \text{ cm} + 117 \text{ cm}$$

$$H_6 = 371 \text{ cm}$$

- 1410002 Rooftile bracket V2 without lead
- 1410003 Rooftile bracket V2 with lead
- 1410004 Roof bracket plain tile without lead
- 1410005 Roof bracket plain tile with lead

If high snow loads are to be expected, the fastening hooks have to be mounted above the rafters (that means that the support must lie on the rafter; alternatively, a higher number of fastening hooks can be considered, depending on the load). If the loading capacity in the battens is not given, an assembly on the rafter is recommended.

# Roof-mounted installation on roof-tiles

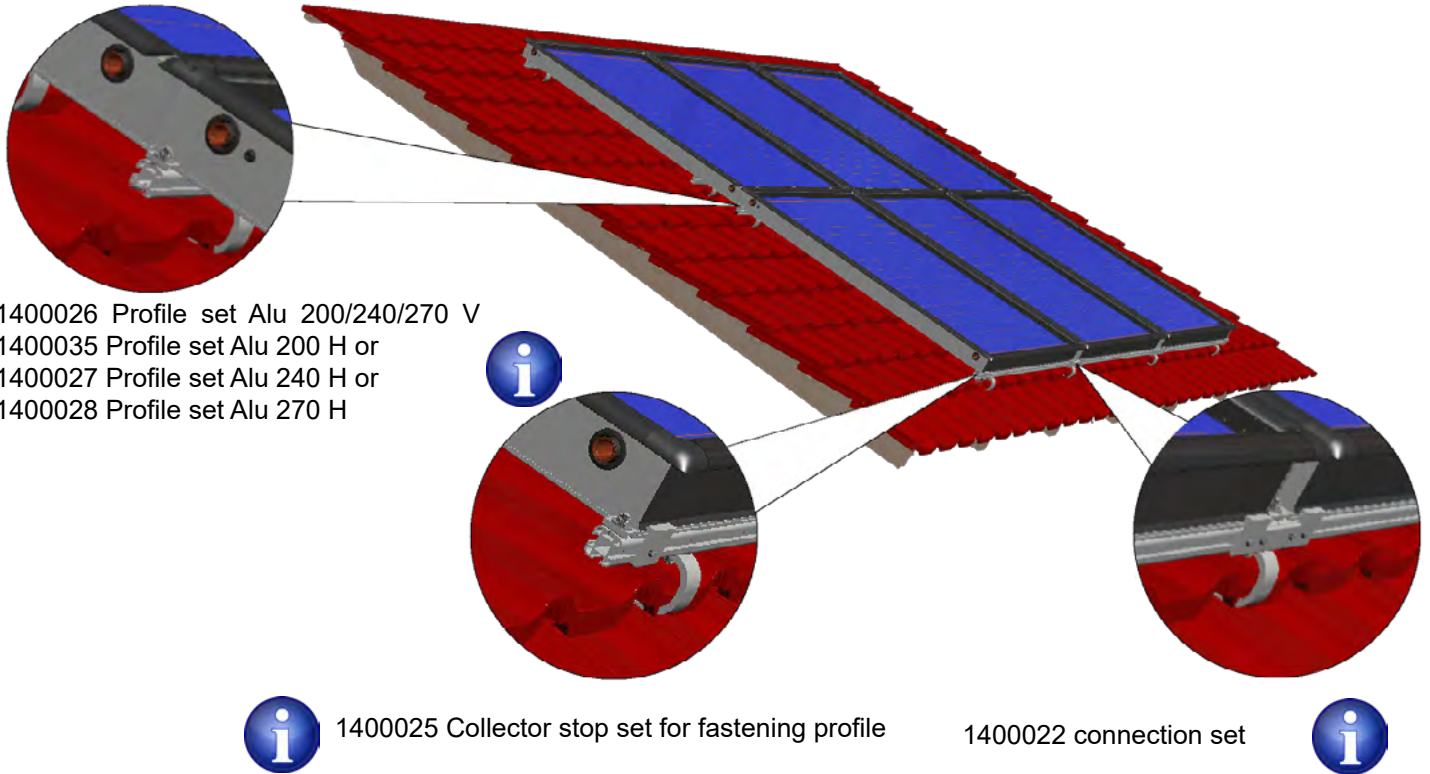

1400026 Profile set Alu 200/240/270 V  
 1400035 Profile set Alu 200 H or  
 1400027 Profile set Alu 240 H or  
 1400028 Profile set Alu 270 H



1400025 Collector stop set for fastening profile

1400022 connection set



For roof-mounted installations, a profile set aluminium 1400034, 1400026, 1400027 or 1400028 (depending on the collector type) as well as one stop set 1400025 is delivered for each collector. If several collectors are mounted in one row, for each collector crossing one connection set 1400022 is necessary.

In case of multi-row systems only in the lowermost row the stop set 1400025 is used. In the other rows the collectors are lying on top of each other.

The stop set has to be mounted in such a way that it is fastened dented at a maximum 20 cm from the outer edge of the collector.

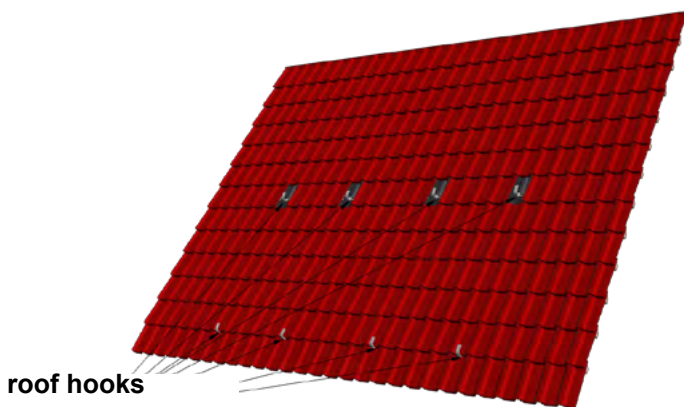

It is possible to combine roof hooks with and without lead cloth. In doing so, roof hooks are used with a crushed brick in the bottom row of the hooks. In the top rows roof hooks are fitted with a lead cloth subsequently.

The installation work is presented in the following pages.

This installation type is suitable for slate, shingle and Prefa sheet metal roof systems and for sheet metal roofs with standing seam.

# Assembly of the roof-tile clamps

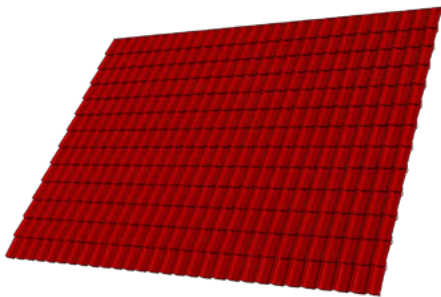

Completely tiled roof

When mounting the roof in regions with high snow load zone of more than 2 kN/m<sup>2</sup>, it is necessary to place the roof hooks in the rafter.



Removal of the tiles after previous determination of the placement of the roof-tile clamps (see page 11 „Spacing multi-row collector fields“).

Fixation of the lower lath 24 x 80 x 600 mm with two screws 5x60 mm.

If the lath is placed near the counter lath, the lath 24 x 80 x 600 mm must not be applied.

1410002 Roof-tile clamp V2 without lead



The lath obligatorily has to be placed in such a way that the hook can be mounted at the lowest point.

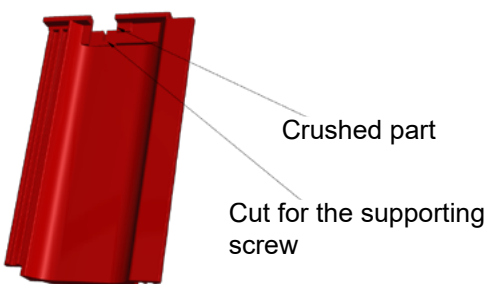

The lower roof-tile must be remounted.

Prior to covering, the lower roof-tile must be grounded coarsely. To avoid a break of the tile, the roof must not rest on the tile.



Mount the tile clamp support 80 x 270 x 30 mm and fix it with two screws 5 x 60 mm.

# Assembly of the roof-tile clamps



In addition to the grinding of the roof-tiles we recommend using a screw which will be mounted on the roof-tile clamp support as a distance saver.

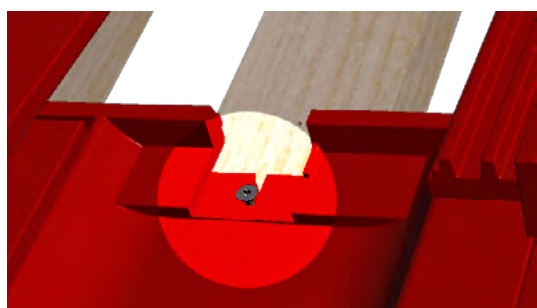

Mounted screw as a distance saver.

If necessary, caulk the coarsely ground brick with a foam tape as a protection against water.



Fix the roof-tile clamp with the support of 50 x 150 x 5 mm using two screws 5 x 60 mm.

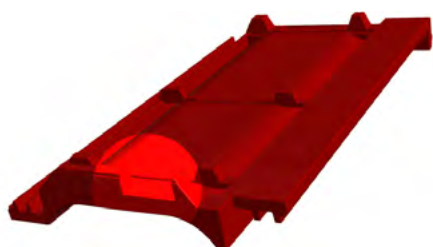

Prior to roofing the covering tile has to be grounded coarsely.

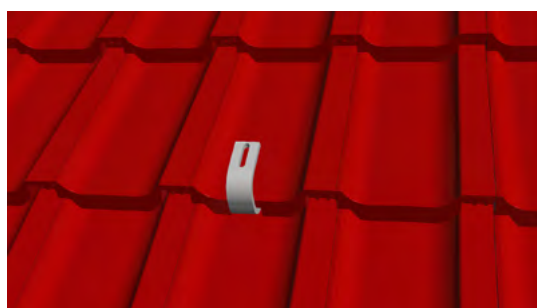

Completely covered roof-tile clamp after covering.

Further roof-tile clamps in one row have to be adjusted exactly (e. g. by a line mark).

# Assembly of the roof-tile clamps with lead cloth

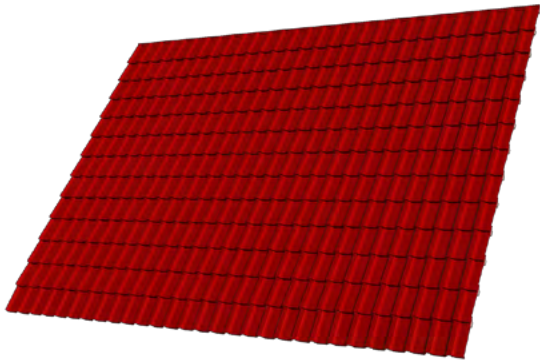

Completely tiled roof.

Removal of the tiles after previous determination of the placement of the roof-tile clamps (see page 11 „Spacing multi-row collector fields“).

When mounting the field in regions with high snow load zone of 2 kN/m<sup>2</sup>, it is necessary to place the roof hooks in the rafter area.

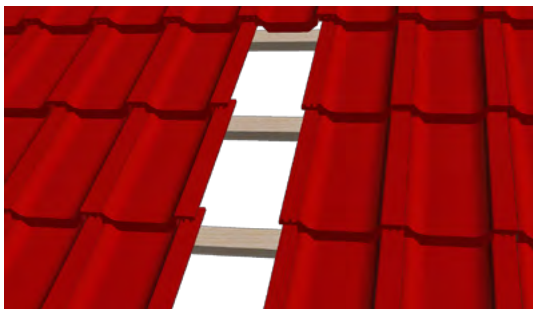

Completely lifted area for the placement of a hook.



Mount the lower lath 24 x 80 x 600 mm with two screws 4 x 50 mm.

If the lath is placed near the counter lath, the lath 24 x 80 x 600 mm must not be applied.

1410003 Roof-tile clamp V2 with lead



Replace the lower roof-tile.

Afterwards the tile clamp support 24 x 150 x 270 mm has to be fixed with two screws 6 x 60 mm.

# Assembly of the roof-tile clamps with lead cloth



Place the first mounting tab in such a way that the lower tile is covered. Additionally make sure that the mounting tab is put sideways under the adjacent tiles (bend up mounting tabs sideways).



The roof-tile clamp must not cover the lower tile. Otherwise a pressure point on the lower tile may arise. 



Mount the upper mounting tab. Bend it up sideways. The screws of the roof-tile clamp have to be covered. Protect the mounting tab against slipping (e. g. by seaming it to the upper lath).

The lead cloth has to be positioned in a way that it is overlapped by the roof tile. 



The added foam wedge is placed under the adjacent tiles on both sides as well as above (protection against splashing water and snow).



Completely mounted roof-tile clamp.

Further roof-tile clamps in one row have to be adjusted exactly (e. g. by a line mark). 



# Assembly of the roof-tile clamps for plain tile

The roof-tile clamp for a roof-mounted assembly with a plain tile covering is also usable for roofs with slate, shingle and Prefa sheet metal roof systems.



Fixture of the lower lath 24 x 80 x 600 mm with two screws 4 x 50 mm.

If the lath will lie in the area of the main lath, the lath 24 x 80 x 600 does not apply.

The roof-tile bracket has to be adjusted in a way that only one tile has to be grinded. Vertically, the roof has to be adjusted in a way that one capping tile has enough space for not having to be grinded.

The roof hook will be fixed with two screws 5 x 60 mm. The roof-tile bracket must not lie on the tile or leave pressure marks on it.

If the roof-tile bracket will find a too deep lying position, the delivered lumbers of 5 mm have to be laid under the hook.

When mounting the field in regions with high snow load zone of more than 2 kN/m<sup>2</sup>, it is necessary to place the roof hooks in the rafter area.



Tile the complete brick laterally.

Grind the brick and tile the roof afterwards.

Tile the roof with all the remaining bricks.

Any other roof-tile clamps have to be lined up in a row.



1410004 Roof-tile bracket V2 plain tile completely without lead

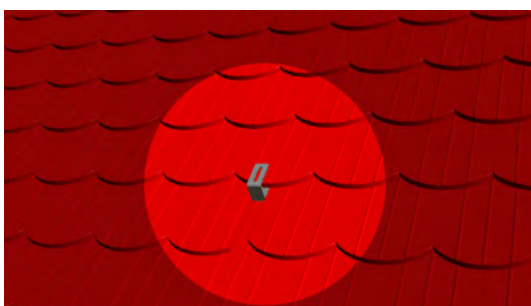

# Assembly of the plain tile clamps with lead

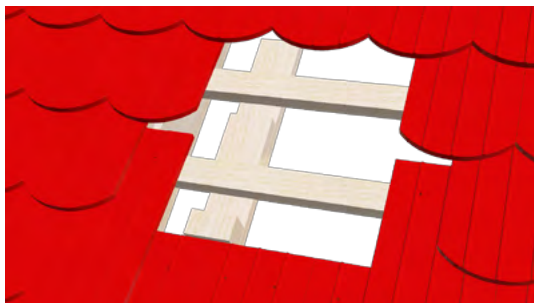

Fixation of the lower lath 24 x 80 x 600 mm with two screws 5 x 60 mm.

When mounting the field in regions with high snow load zone of more than 2 kN/m<sup>2</sup>, it is necessary to place the roof hooks in the rafter area.



Assembly of the lower tile clamp support 80 x 50 x 45 mm with two screws 5 x 60 mm.

When assembling, there will be a timber excess length of 5 mm (timber will be higher than tile).

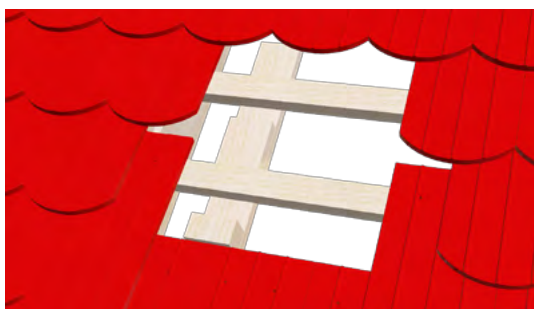

Completely mounted timber supports.



Mounting of the lower lead sheet while placing the lead laterally under the tiles.

# Assembly of the plain tile clamps with lead



Make sure that the corners of the lead sheet are bent under the tile to avoid a slipping off.

1410005 Roof-tile clamp V2 plain tile with lead



Fixation of the roof-tile clamp with two screws 5 x 60 mm.

Screw the lower one into the tile lath and the upper one into the tile clamp support.



Completely mounted roof-tile clamp with lower lead sheet.

The tile clamp must have a minimum distance of 5 mm to the underlying tile.



Mount the upper lead sheet while placing the lead laterally under the tiles.

Make sure that the corners are bent under the tile on both sides to avoid a slipping off.

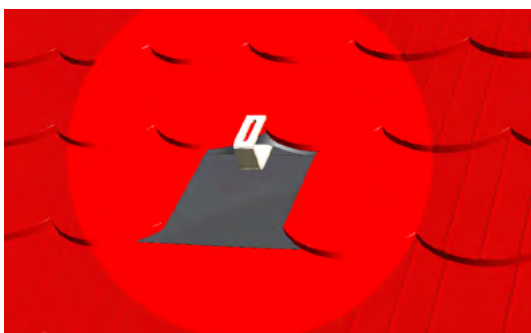

Covering of the upper tiles.

Completely mounted roof-tile clamp.

Further roof-tile clamps in one row must be adjusted exactly (e. g. by a line mark).



# Assembly roof-tile clamps for corrugated sheet

The screws contained in the set are suitable for roofs with a wooden substructure. In case of a metal substructure, the fasteners have to be provided by the customer.



Make sure that the clamps are placed near an existing substructure.

1410001 Roof-tile clamp corrugated V2



The holes for the fixation screws have to be pre-drilled with an 8 mm borer.

The fixation of the clamps is realised with frontage screws 6,5 x 100 mm with sealing gasket.

Depending on the width of the substructure underneath the corrugated roof covering, the roof clamp can additionally be fixed with the second fastening screw.



Completely mounted roof clamp which is ready for the assembly of the fastening profiles.

If the roof clamps cannot be mounted within the limits indicated (see „spacing roof hooks“), you have to mount horizontal or vertical STI system profiles onto the roof clamp first of all. Afterwards the supplied fastening profiles can be mounted.

# Assembly of the fastening profiles

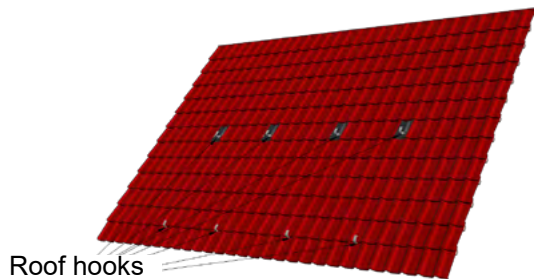

Pre-assembled roof-tile brackets for a collector field of two collectors.

Above: Roof-tile brackets left out and hook set assembled with an assembly edge.

Below: Grinded bricks and hooks assembled without an assembly edge.

Assembling sequence profile set:



Profile set Vario Fix 200 V, 240 V, 270 V  
 Profile set Vario Fix 200 H  
 Profile set Vario Fix 240 H  
 Profile set Vario Fix 270 H

Profile set Alu 200 V, 240 V, 270 V  
 Profile set Alu 200 H  
 Profile set Alu 240 H  
 Profile set Alu 270 H

Profile set Vario Fix 200 V, 240 V, 270 V  
 Profile set Vario Fix 200 H  
 Profile set Vario Fix 240 H  
 Profile set Vario Fix 270 H

# Assembly of the fastening profiles



1400022 Connection set for profile set



In the edging area of the fastening profiles which have to be mounted, the connecting profiles will be inserted and centred. The connecting profile will be mounted in every collector row.

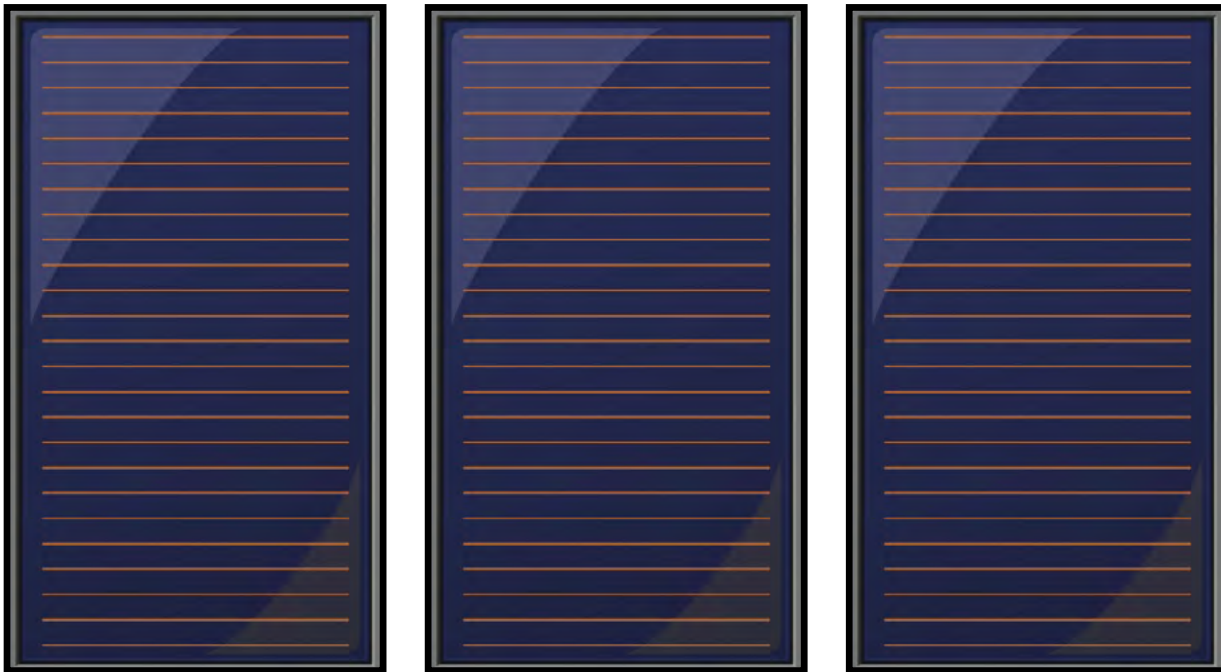

1400025 Arrester set for profile set



For every collector, two stop profiles with a length of 5 cm are available. They serve for the stability of the collectors until the final fixation of the collectors. Each fastening happens with an indenting distance of max. 20 cm from the end of the collector.

The stop profiles are only delivered and assembled in the lowest row.

# Assembly of the fastening profiles

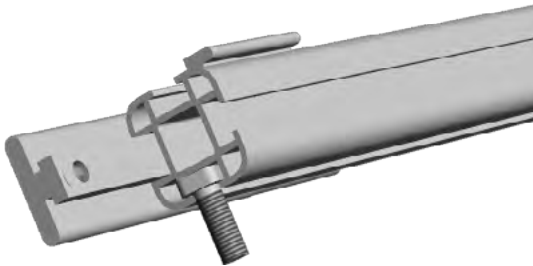

Afterwards, insert the square-head bolt 90° offset to the connecting profile into the notch for an assembly with the rooftop bracket.

1400023 Fastening profile on roof hooks (2 fastening points)

1400024 Fastening profile on roof hooks (4 fastening profiles)

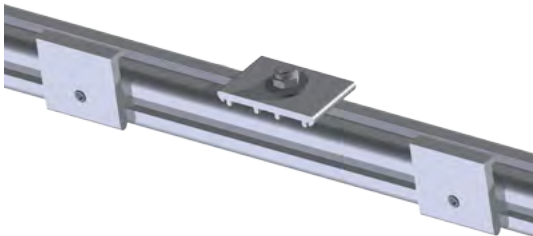

Place the premounted rail clips for the fastening of the profiles in the upper and lower profile rail. The rail clips will be positioned at the height of the collector junction.

1400021 Collector fastening set Profile



Connect the premounted profile rails with the connector. Fix all setscrews M8 x 12 mm in the connectors as well as the collector stop set.

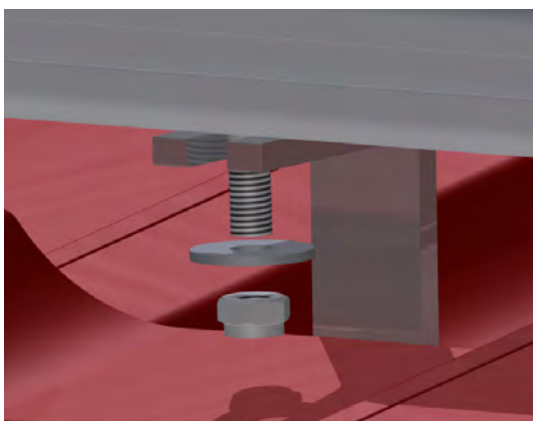

Mount the profile rails on the roof hooks. Therefore, insert the square-head bolt through the elongated hole in the roof hook and fix it with the washer and the bolt nut.

The maximum torsional moment of 17 Nm for the connection of the self-retaining nut bolt M8 and the square-head bolt M8 for the assembly in the fastening profile must not be exceeded.

The elongated holes in the roof hooks serve as a compensation of unevennesses on site.

Prior to the final assembly of the fastening profiles on the roof hooks, the exact position has to be checked (bubble level etc.).

# Assembly of the fastening profiles

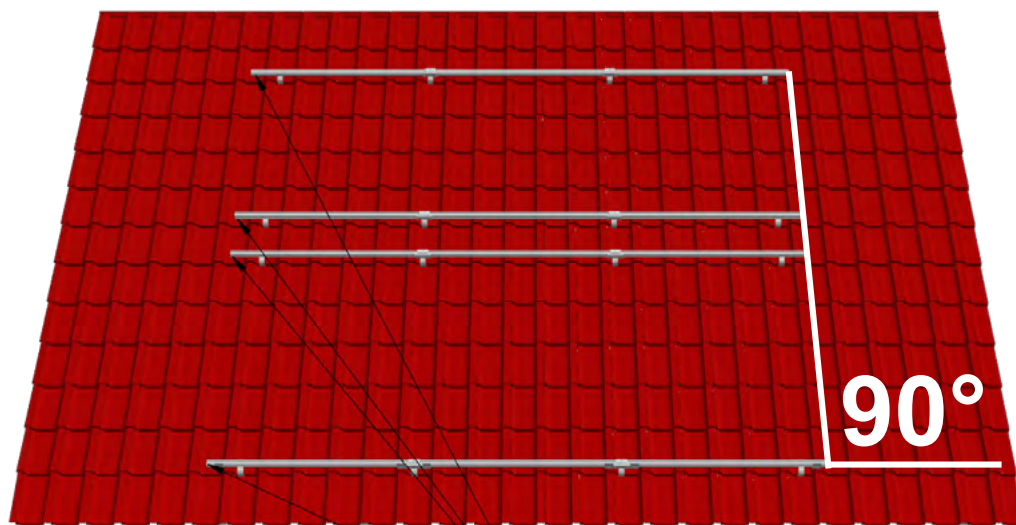

Ends of profile set aluminium lie flush against each other.

Completely mounted fastening profiles which are prepared for the assembly of the collectors. Pay attention to the conclusive alignment of the profile rails.





# Assembly preparation - sequence

## Single-row collector field

When assembling single-row collector fields, the collectors will be mounted starting with the respectively outer collector. The exact assembly of the collectors will be described starting with page 29.

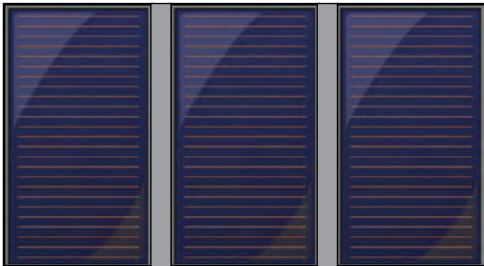

Single-row collector field

## Assembly sequence

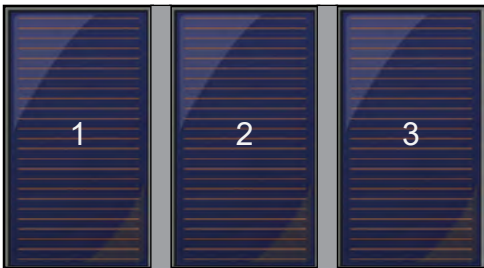

or



## Multi-row collector field

When assembling multi-row collector fields, the collectors which are located one above the other will be mounted first of all. After placing the first collector, the second collector will be adjusted above the first one. The collectors which are lying one above the other have to be aligned accurately. The exact assembly of the collectors will be described starting with page 29.



Multi-row collector field

# Assembly preparation - sequence

## Assembly sequence

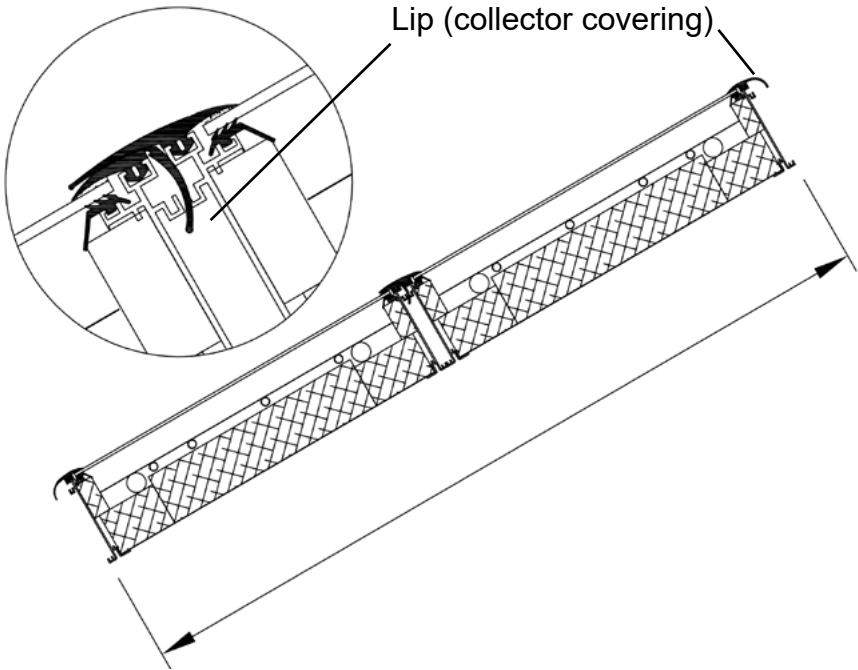
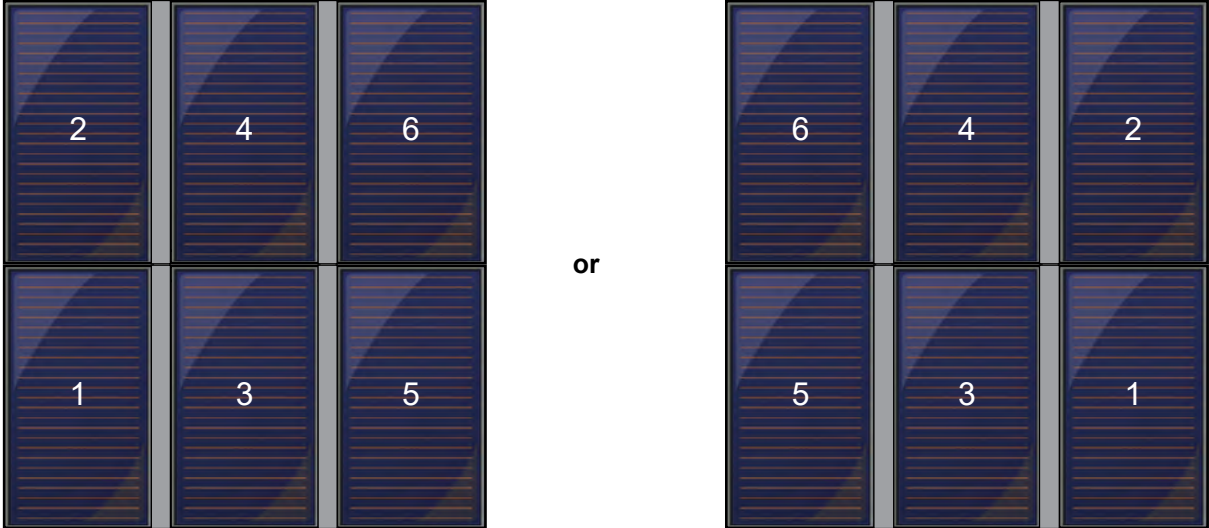

In case of multi-row installations, the collectors have to be mounted adjoining. The lip (collector covering) of the top collector is set over the lower collector. The lip (collector covering) of the lower collector is clamped into the joining area which guarantees an optimum waterflow.

# Assembly of the intermediate plates/ multi-row collector fields

## Multi-row collector fields with intermediate plates

To attain a homogenous appearance of the collector installation, the assembly of sheets between the collectors is possible. The intermediate plates are exclusively assembled due to optical aspects and do not have a functional impact on the installation. This is the reason why the intermediate plates can be ordered optionally and are not necessarily included in the delivery contents.

When assembling multi-row collector fields, the collectors in the rows above the other rows will always be mounted edge to edge. To subsequently be able to assemble the intermediate sheets without any problems, the lip (collector covering) of the lowest collector has to be cut out at the respective parts.

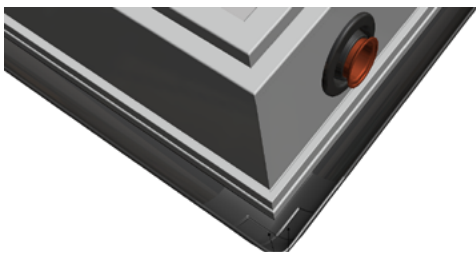

Prefabricated cuts at the bottom of the collector covering



For the assembly of the intermediate plate, the prepared cut of the lip (collector covering) will be cut out at the respectively lowest collector. Thereby, you have to pay attention that only the cuts which lie horizontally will be cut out. Cuts will only be processed where an intermediate plate will be assembled.

For the assembly of the collectors in multiple rows as well as for the assembly of curved intermediate plates, the processing at the outside of the collector field is necessary as well.

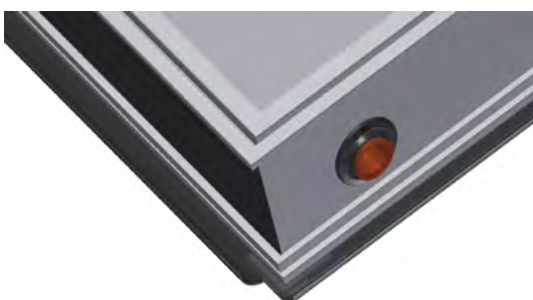

The cuts which have to be made are marked at the bottom:

V: Cut for vertical collectors

H Cut for horizontal collectors

Cut out the lip (collector covering) with a knife at the respective and prepared cuts.

# Assembly of the intermediate plates

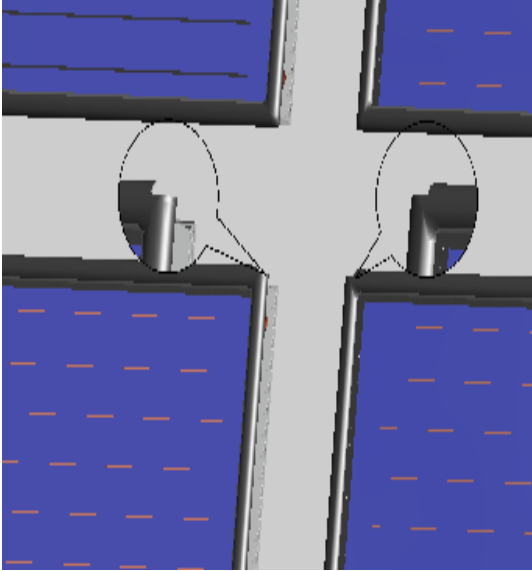

By a removal of the lip (collector covering) at the designated position, the intermediate plates can be mounted easily.

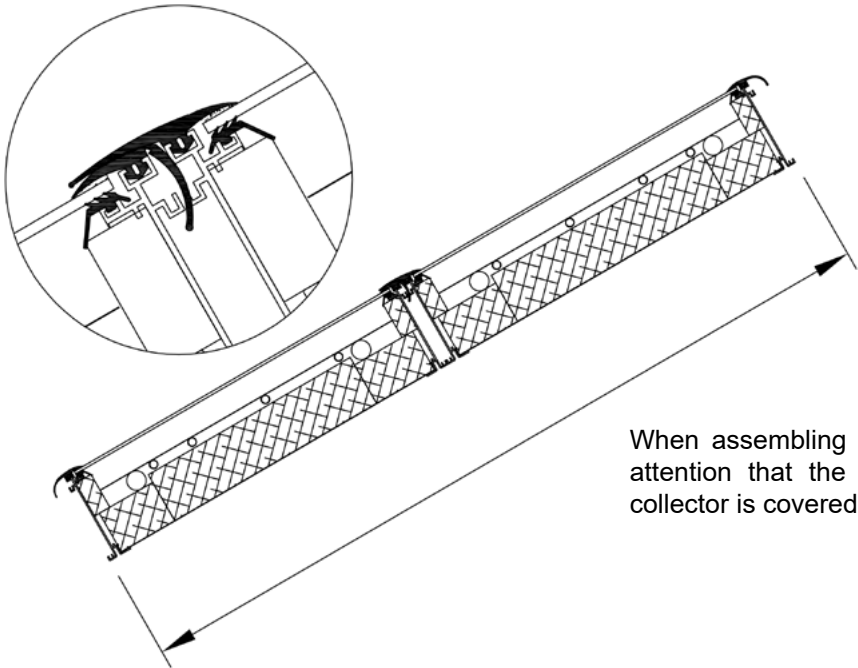

When assembling the upper collector, you have to pay attention that the lip (collector covering) of the lower collector is covered by the upper collector.

The assembly of the collectors will be described in the following. The assembly of the intermediate plates is described on page 37.

# Assembly of the solar collectors

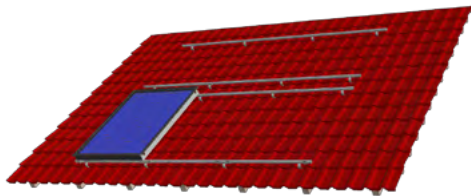

Place the first collector. To do so, place it on the upper section rail and drop it on the lowest one.

Be aware of not damaging the back panel by protruding devices.

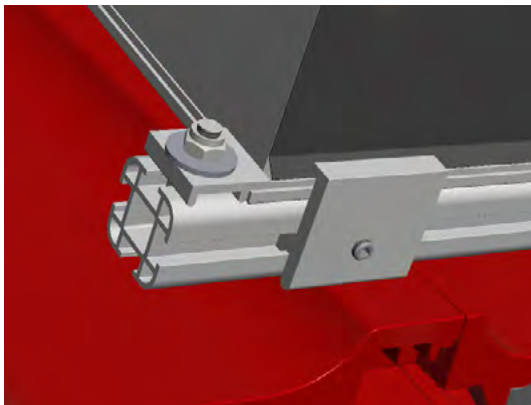

At the outside of the collector, the mounting plate „onefold“ will be inserted and fixed directly at the profile end (succintly).



1400020 Collector connection set profile edge

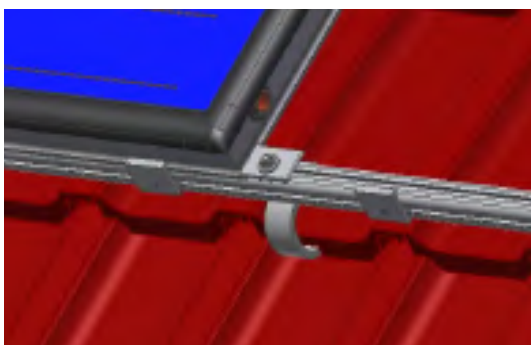

1400021 Collector fastening set profile



All of the following screws to mount the collector can only be fixed after the installation of the hydraulic collector connectors.

The previously inserted collector connection clamp „double“ should be moved until it stops at the collector. Then the square head bolts could easily be screwed with the u-disc and the nut M8.

# Assembly of the solar collectors



Before the following collector can be assembled, the hydraulic collector connection has to be mounted with the conclusively protruding collector connection.

1300002 Collector connection set  
hydraulically pluggable

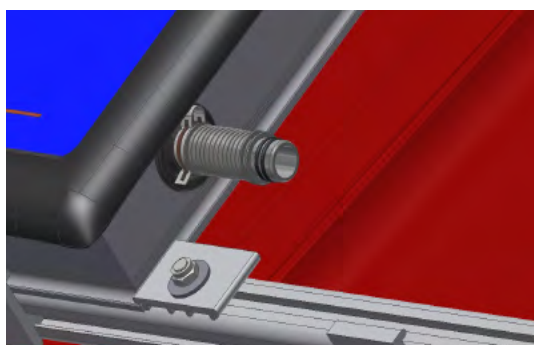

Insert the hydraulic collector connection into the manifold. In so doing, make sure that the two O-rings are assembled. Insert the connector all the way in and fix it with the locking spring.

At the top and lower end of the collector connection, the hydraulic collector connector will be premounted as you can see in the image alongside.

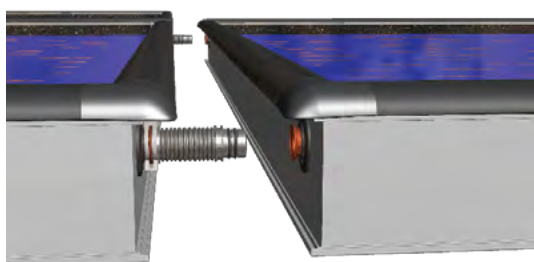

Move the next collector to the already existing one. In doing so, please make sure that the stretching compensator is inserted properly all the way into the collector manifold.

# Assembly of the solar collectors

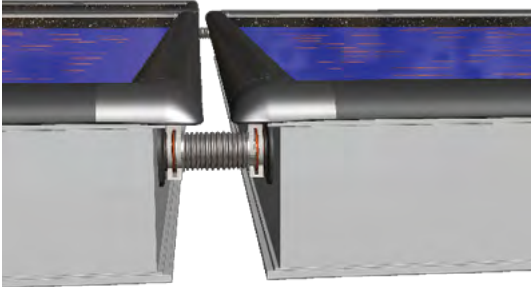

Fix the stretching compensator with the locking spring.



Tighten the bolt nut at the mounting plate „twofold“ firmly. The torsional moment of 17 Nm must not be exceeded.

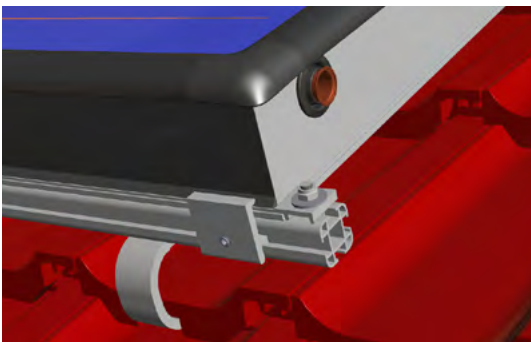

Fix the mounting plates „onfold“ at the end and tighten the bolt nut. The torsional moment of 17 Nm must not be exceeded.

# Assembly of the probe

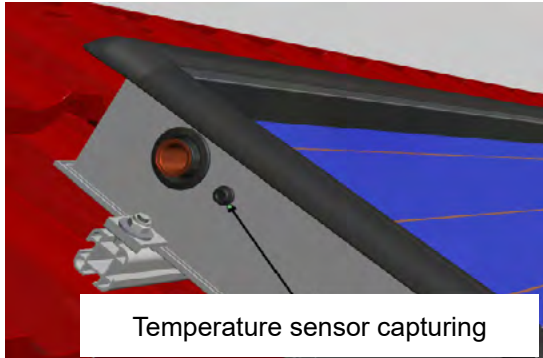

Every collector is equipped with a sheath for the positioning of a temperature sensor.

The position of the temperature sensor is located below the upper left manifold outflow or to the left of the sticker with the label „above“ at the outside of the frame profile. The sheath for the insertion of the sensor is protected by a silicone cover which has to be opened with a knife or a screw driver centred before the insertion.

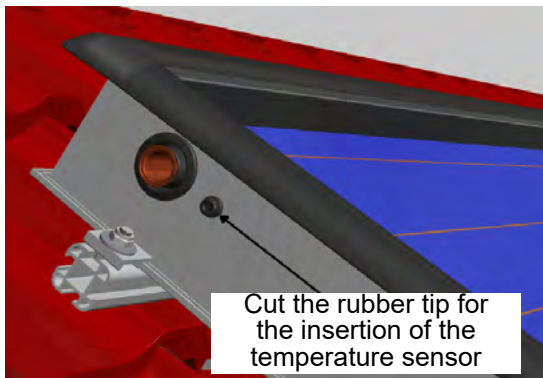

The insertion depth of the sensor is limited to 4 cm. An additional safeguard against a slipping out is recommended.

Due to the measuring point on the absorber, the sensor can be installed at an arbitrarily chosen collector of the collector field.

The measurement deviation of the recorded temperature is  $\pm 2$  K compared with the medium temperature.



# Collector connections

The assembly of the hydraulic system depends on the delivery contents: hydraulic system Standard or hydraulic system Smart Lock System.



The cap will be mounted everywhere where a collector connection is not used.

- 1310209 Cap set (2 pieces complete)
- 1310119 Cap set aluminium (2 pieces complete)

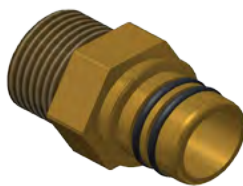

Connection 3/4"

- 1310205 Collector connection set R3/4"  
(2 pieces complete without cap)



Connection for soldering or clamping ring transition

- 1310204 Collector connection set 22 mm  
(2 pieces complete without cap)
- 1310114 Collector connection set 22 mm aluminium  
(2 pieces complete without cap)



Air eliminator without extension

- 1310207 Air eliminator set without extension  
(complete without cap)

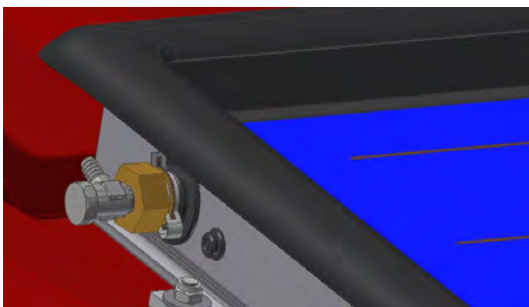

Completely mounted air eliminator.

Any other connections as well as the cap will be assembled in the same way. Make sure not to cover the capture for the temperature sensor.

The imaged air eliminator is only suitable for the application with copper pipes.

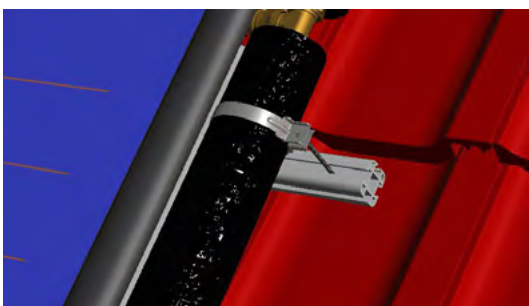

The required connection dimension für the mentioned collector connections has to be calculated by the scheduler of the installation depending on the regional circumstances (lengths of the pipelines, additional resistors etc.)

The connection lines or lateral manifolds should be safeguarded with a clamp in the region of the collector connections on the warm and the cold side for a relaxation of the tension. This has to be carried out by the customer.

# Hydraulic connection with manifold

## Hydraulic connections for multi-row systems

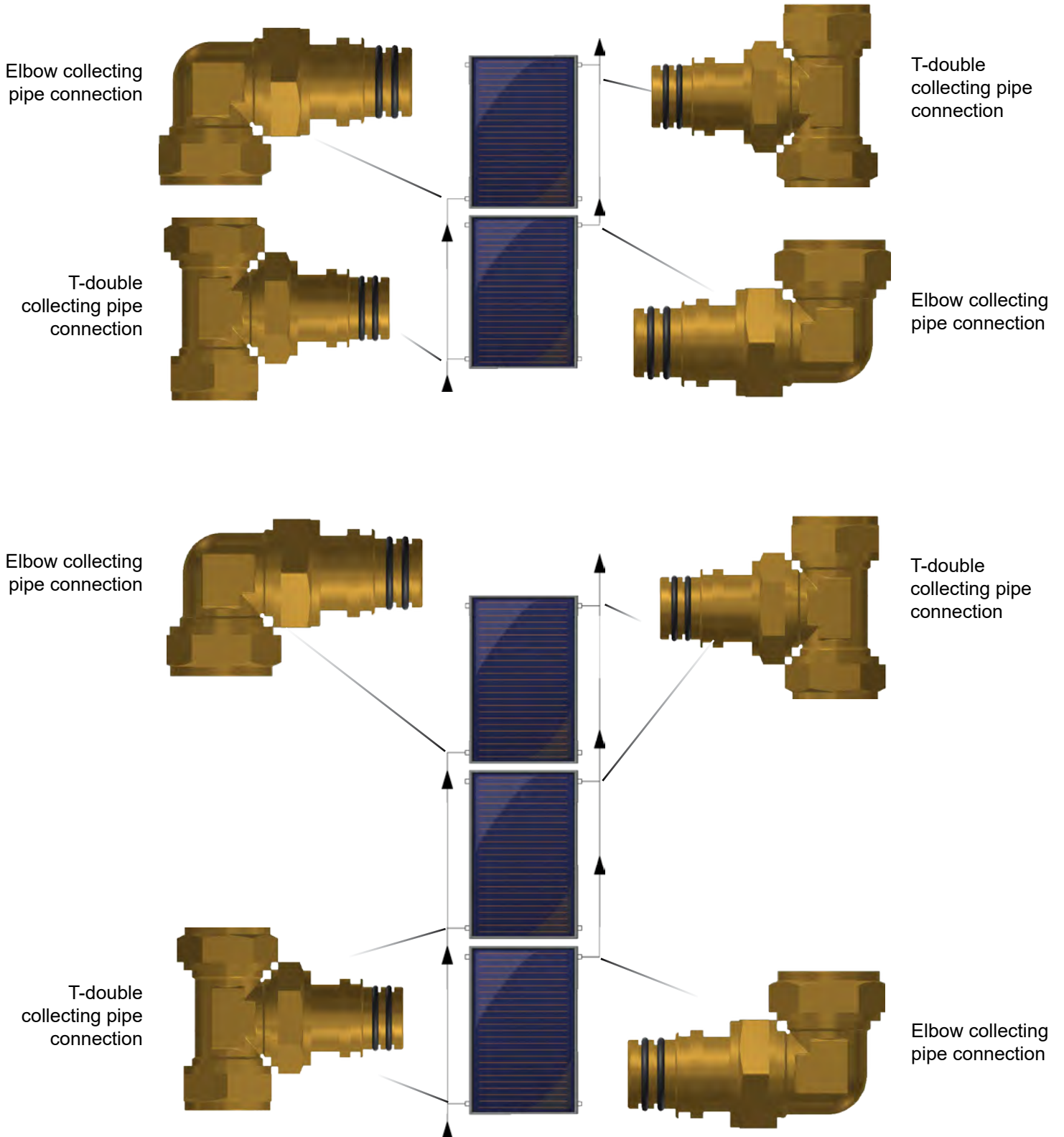

The whole equipment is available from STI.

# Overview hydraulic connections SLS / accessories

## Hydraulic connections



Exhauster connection for the installation at the collector without extension  
Smart Lock System

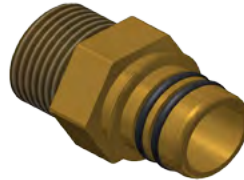

Collector connection 3/4" for thread fittings  
Smart Lock System



Collector connection 22 mm for soldered fittings or clamping ring joints  
Smart Lock System



Collector connection hydraulic (compensator) which connects two collectors and compensates thermal dilations  
Smart Lock System



Clamp collector connection and O-ring seal  
Clamp for connection of the above mentioned hydraulic devices with the flange at the collector

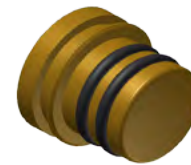

Cap  
Smart Lock System

## Accessories



Tool set



Spare set hydraulic



Assembling spare set

# Overview hydraulic connections / accessories aluminium

## Collector connections aluminium for collectros with aluminium pipe



Collector connection 22 mm  
Aluminium  
Smart Lock System



Cap  
Aluminium  
Smart Lock System



Collector connection hydraulic



Hydraulic connection set  
clamping ring 90 °  
Pressfitting M-Shape



Hydraulic connection T-piece  
Pressfitting M-shape



Safety line

## Notes Al/Al absorber

Please pay attention to the user instructions for the usage of collectors with full aluminium absorbers (aluminium sheet, aluminium pipe) mentioned below:

- All hydraulic connection fittings of the collector have to be made from aluminium or stainless steel.
- Hydraulic system components made from brass and copper must be mounted with a minimum distance of 2,5 m to the collector.
- It is absolutely necessary that neither brass slivers nor copper slivers will be brought into the hydraulic system.
- The solar collector has to be a closed system. Additional air inlet from outside has to be avoided mandatorily. This is the reason why open installations or those which are flushed directly with drinking water are not possible.
- The glycol used has to contain respective inhibitors. Additionally, the guidelines of the producer of glycol have to be observed to assure a long-term protection of the installation.
- Recommended and tested heat transfer medium: Tyfocor ® L of the Tyforop GmbH
- At the solar station, pump or control system, it has to be highlighted that the collectors had been built with a full aluminium absorber.

# Assembly intermediate plates

It is possible to mount metal sheets between the collectors for a homogenous appearance. The distance metal sheets are only assembled for optical aspects and do not have any functional influence on the system. Therefore, the distance metal sheets have to be ordered separately and are not necessarily included in the delivery.

## Distance metal sheets for the assembly in one row



For the collector types FKF 200 V, FKF 240 V and FKF 270 V, two distance metal sheets are mounted in every gap between the collectors. For the collectors FKF 200 H, FKF 240 H and FKF 270 H, the assembly of one distance metal sheet is planned. In case of multi-row systems, the distance metal sheets are mounted as described. The distance metal sheets can be mounted from above or below.

## Distance metal sheet

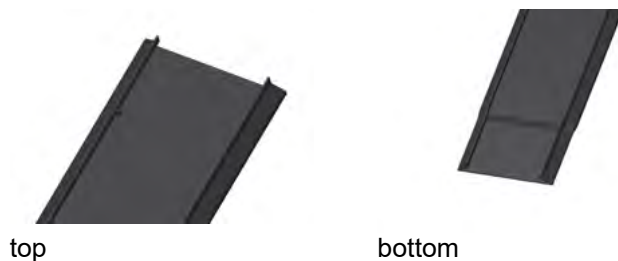

We recommend not to assemble the distance metal sheets at a high insolation or temperature.

The potential thermal expansion of the collector may cause difficulties when assembling.

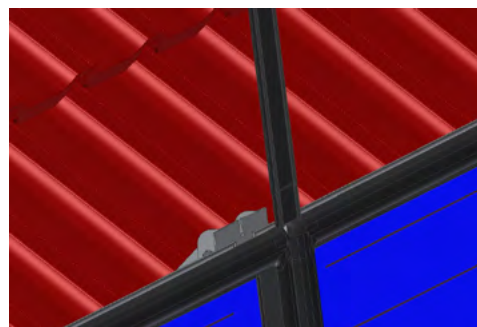

The distance metal sheet is inserted into the collector grooves from above/below.

In case of vertical collectors or rather in case of multi-row assembly of the collectors, further distance metal sheets are inserted subsequently from above/below.

The distance metal sheet has to be inserted until it lines up precisely with the lip (collector covering).

When assembling the distance metal sheets, please pay attention to the waterflow from the upper to the lower distance metal sheet.

1200531 Distance metal sheet FKF 200 V top

1200532 Distance metal sheet FKF 240 V top

1200533 Distance metal sheet FKF 270 V top

1200534 Distance metal sheet FKF

200 H / 240 H / 270 H top

1200535 Distance metal sheet FKF 200 V bottom

1200536 Distance metal sheet FKF 240 V bottom

1200537 Distance metal sheet FKF 270 V bottom

1200538 Distance metal sheet FKF

200 H / 240 H / 270 H bottom



To avoid injury, it is recommended to use a piece of wood to push the distance metal sheets into the collector grooves.

The distance metal sheet will be stuck into the collector groove to protect it against slipping out. The silicone strip should have a length of 10 - 20 cm. Please note that the distance metal sheet must be free of silicone residue to ensure the flow of rainwater.

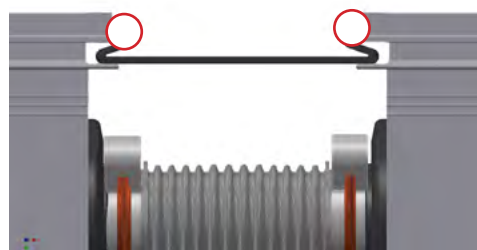

# Assembly of the roof implementation set

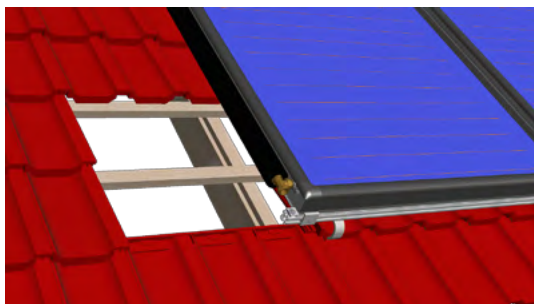

For the assembly of the roof implementation, the roof tiles have to be removed at the assembly site.

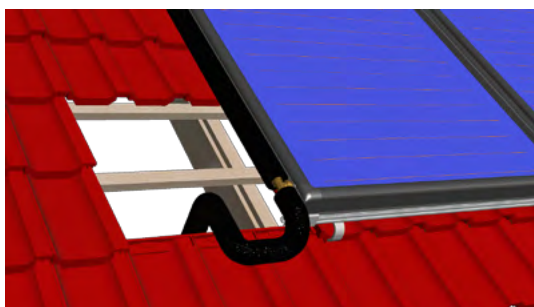

The connection pipe will be conducted through the roof and afterwards will be connected with the collector connection.

1210900 roof feed-through set  
1320303 connection pipe 2,5 m  
1320304 connection pipe 15 m  
1320311 safety pipe

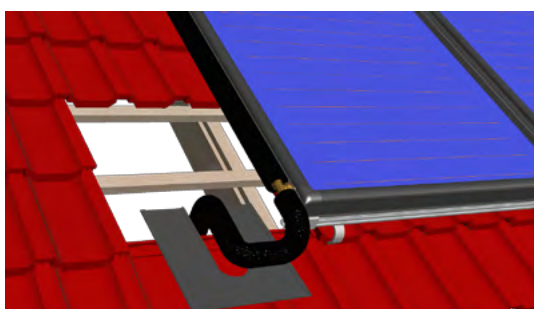

The bottom part of the roof implementation set will be extracted with the lead apron.

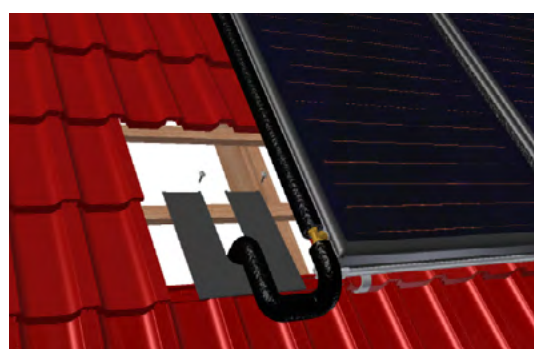

The bottom part will be connected with the connection pipe and fixed with screws.

# Assembly of the roof implementation set

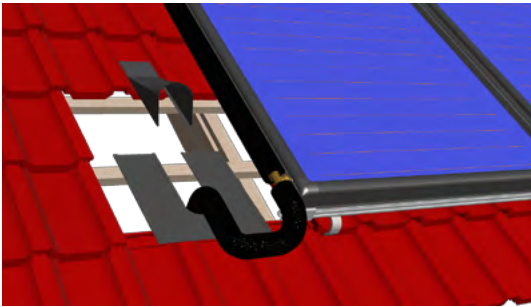

In the next step, the sheet metal cover will be slid from above.

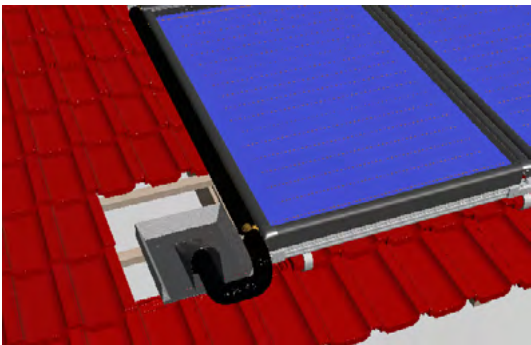

Finally, the delivered sealing wedge will be fixed in the upper part of the roof implementation set. When fixing, you have to pay attention that the underground (plate) is dry, dustless and dirt-free!

Depending on the roofing, the fixation of the sealing wedge might not apply (e. g. shingle roof).

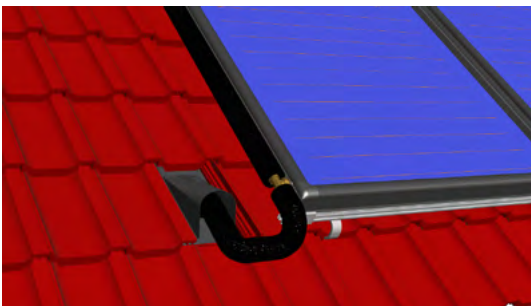

In the last step, the roof tiles have to be inserted again.

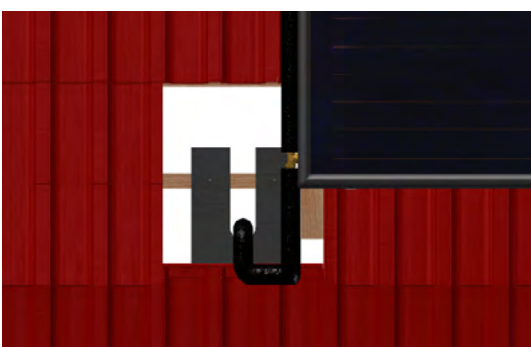

If the assembly of a Drain Back system (STI SolBox) is going to take place, the roof implementation (return pipe) has to be mounted below the collector connection.

# Assembly of the connecting pipe



The connecting pipe can be adjusted individually. To do this, the corrugated pipe from stainless steel has to be cut into the appropriate length. For this purpose, please use a pipe cutter. Check the pipe ends for impurities, deformations and the absence of burrs.

Please be aware that only the connecting pipe DN20 l = 15 m can be adjusted individually. Any other corrugated pipe lines from stainless steel of the STI programme will be delivered in fixed lengths.



1320304 Connecting pipe DN20 l=15 m,  
PES insulation

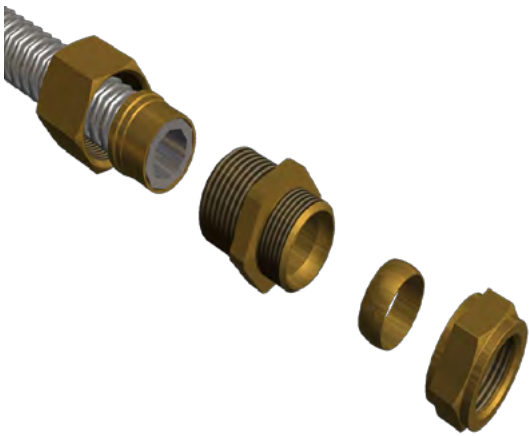

In the next step, the components will be slid onto the pipe ends according to the drawing alongside. Please pay attention that the pipe will be pushed all the way through the clinching ring into the fitting. Fasten the screwcap finger tight. Afterwards, the bolt nut has to be tightened by 3 1/2 to 4 turns with appropriate wrenches.

Generally, the whole connection has to be verified for imperviousness according to the recognized valid rules of engineering after conclusion.

Readily mounted connection pipe with screwing.

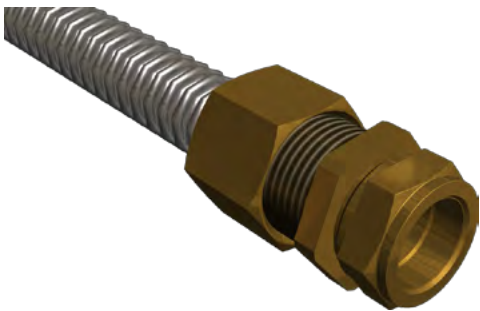

1320320 Connection set for connection pipe  
22 mm connector

1320321 Connection set for connection pipe  
22 mm screwing



Readily mounted connection pipe with connector.

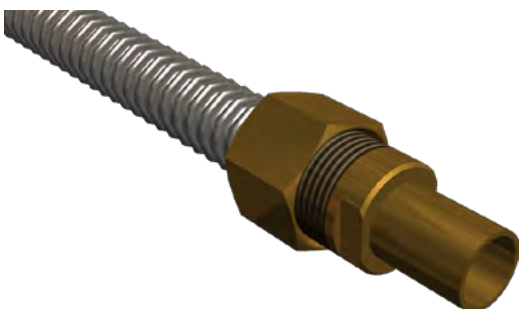



# SnapCover



The assembly of the intermediate plates is absolutely necessary when using the SnapCover.



After having assembled the intermediate plates, the assembly starts at the lower left corner. An exact order of the assembly including a labelling of the sheets will be described on page 44. Numbered sheets are included in the scope of delivery.

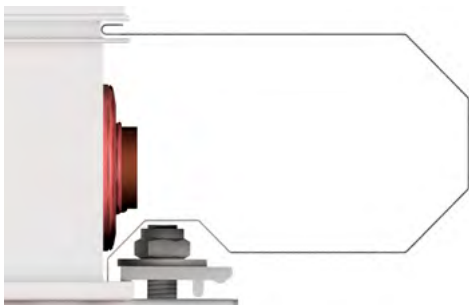

All SnapCover sheets will be assembled in the same way. At first, the plate will be hooked into the lower collector frame. Afterwards, the fold of the sheet has to be clicked into the recess of the upper collector frame.

There are three slight elevations at this fold which have to snap into the frame and therefore secure the sheet against slipping out.

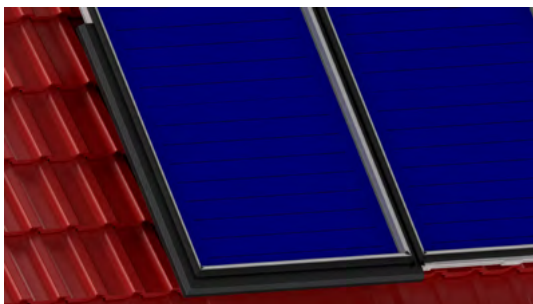

After having assembled the eaves flashing, the first side plate will be assembled at the same corner. This installation takes place analogous to the assembly of the eaves flashing.

It is absolutely necessary to pay attention to the labelling of the sheets and to the assembly sequence (sketch see page 44).



Move the eaves sheet and the side plate until there will be a closed corner.

# SnapCover



After having completed the left corner, the extension sheets of the eave will be assembled.

In doing so, please start from the left side. The sheets can be moved but will be limited by the recess in the plate and thus by the collector frame.



The assembly of the right corner happens analogous to the assembly of the left corner. First of all, the eave sheet has to be mounted.



After that, the assembly of the side plate takes place. It has to be taken care that the result will be a closed edge.



Top view of the assembled eave flashings with side plates.



# SnapCover

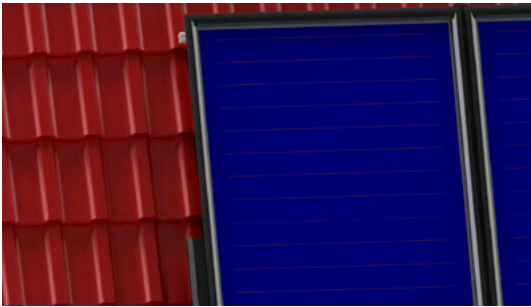

When the eave sheets and the lower side plates will be assembled and aligned properly, the extension of the side plates can take place (only in case of vertical collectors or multi-row collector fields).

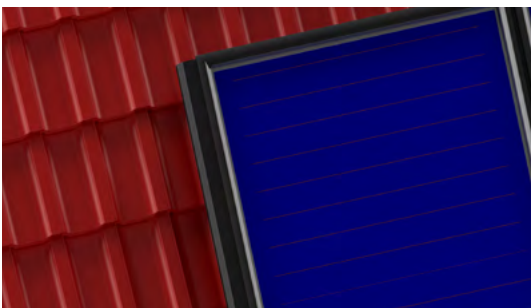

The side plates will be clicked into the collector frame and then be evenly pushed over the lower side plate from above.

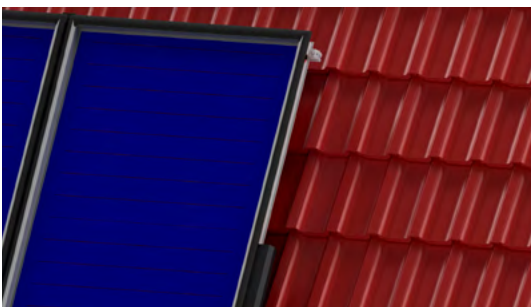

The assembly takes place on both sides of each collector row.

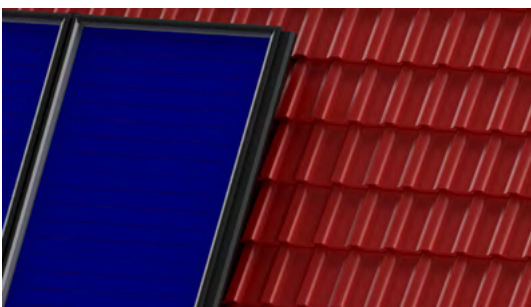

Completely mounted side plate on the right side.



Completely mounted SnapCover.

# SnapCover - assembly sequence

## Vertical assembly

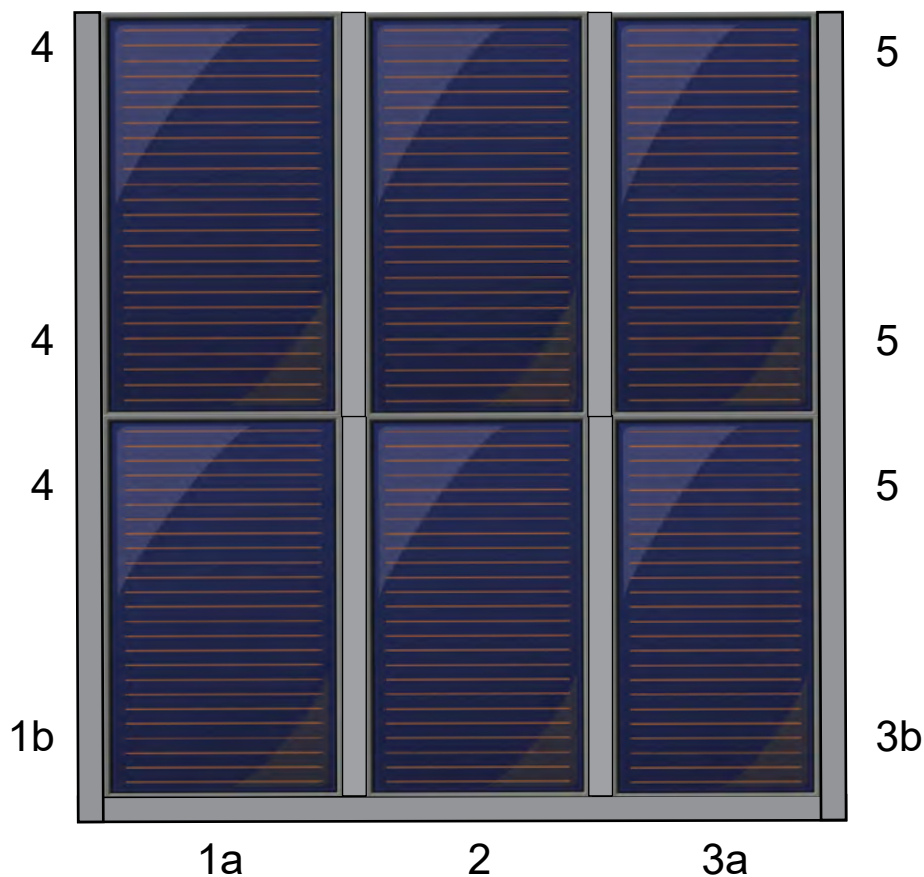

1210401 SnapCover FKF 200 V BLS 2x1  
 1210402 SnapCover FKF 200 V ER - 1  
 1210403 SnapCover FKF 200 V ZR - 1

1210411 SnapCover FKF 240 V BLS 2x1  
 1210412 SnapCover FKF 240 V ER - 1  
 1210413 SnapCover FKF 240 V ZR - 1

1210421 SnapCover FKF 270 V BLS 2x1  
 1210422 SnapCover FKF 270 V ER - 1  
 1210423 SnapCover FKF 270 V ZR - 1



## Horizontal assembly

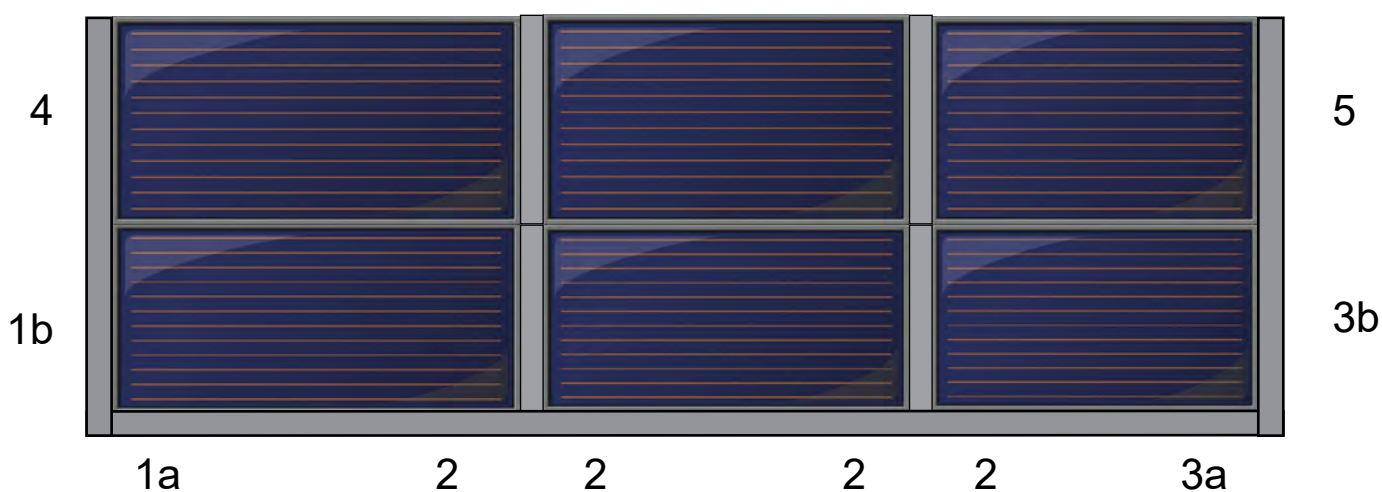

1210405 SnapCover FKF 200 H BLS 2x1  
 1210406 SnapCover FKF 200 H ER - 1  
 1210407 SnapCover FKF 200 H ZR - 1

1210415 SnapCover FKF 240 H BLS 2x1  
 1210416 SnapCover FKF 240 H ER - 1  
 1210417 SnapCover FKF 240 H ZR - 1

1210425 SnapCover FKF 270 H BLS 2x1  
 1210426 SnapCover FKF 270 H ER - 1  
 1210427 SnapCover FKF 270 H ZR - 1



# Pipe dimension of the connecting pipe

## Recommended pipe dimension of the connecting pipe

Length of pipe F + BF Number of collectors	up to 10 m	from 10 m to 15 m	from 15 m to 20 m
	2 coll. - 132 L/h	12 x 1	15 x 1
3 coll. - 198 L/h	15 x 1	15 x 1	15 x 1
4 coll. - 264 L/h	15 x 1	18 x 1	18 x 1
5 coll. - 330 L/h	18 x 1	18 x 1	18 x 1
6 coll. - 396 L/h	18 x 1	18 x 1	22 x 1
7 coll. - 462 L/h	22 x 1	22 x 1	22 x 1
8 coll. - 528 L/h	22 x 1	22 x 1	22 x 1
9 coll. - 594 L/h	22 x 1	22 x 1	22 x 1
10 coll. - 660 L/h	22 x 1	22 x 1	22 x 1
11 coll. - 726 L/h	22 x 1	22 x 1	28 x 1,5
12 coll. - 792 L/h	22 x 1	22 x 1	28 x 1,5
13 coll. - 858 L/h	22 x 1	28 x 1,5	28 x 1,5
14 coll. - 924 L/h	22 x 1	28 x 1,5	28 x 1,5
15 coll. - 990 L/h	22 x 1	28 x 1,5	28 x 1,5

The data refer to the plain tube. With corrugated pipe we recommend to choose the larger dimension!



Length of pipe F + BF Number of collectors	from 20 m to 25 m	from 25 m to 30 m	from 30 m to 35 m	from 35 m to 40 m
	2 coll. - 132 L/h	15 x 1	15 x 1	15 x 1
3 coll. - 198 L/h	18 x 1	18 x 1	18 x 1	18 x 1
4 coll. - 264 L/h	18 x 1	18 x 1	18 x 1	22 x 1
5 coll. - 330 L/h	22 x 1	22 x 1	22 x 1	22 x 1
6 coll. - 396 L/h	22 x 1	22 x 1	22 x 1	22 x 1
7 coll. - 462 L/h	22 x 1	22 x 1	22 x 1	28 x 1,5
8 coll. - 528 L/h	22 x 1	22 x 1	28 x 1,5	28 x 1,5
9 coll. - 594 L/h	22 x 1	28 x 1,5	28 x 1,5	28 x 1,5
10 coll. - 660 L/h	28 x 1,5	28 x 1,5	28 x 1,5	28 x 1,5
11 coll. - 726 L/h	28 x 1,5	28 x 1,5	28 x 1,5	28 x 1,5
12 coll. - 792 L/h	28 x 1,5	28 x 1,5	28 x 1,5	28 x 1,5
13 coll. - 858 L/h	28 x 1,5	28 x 1,5	28 x 1,5	28 x 1,5
14 coll. - 924 L/h	28 x 1,5	28 x 1,5	28 x 1,5	35 x 1,5
15 coll. - 990 L/h	28 x 1,5	28 x 1,5	35 x 1,5	35 x 1,5

The data refer to the plain tube. With corrugated pipe we recommend to choose the larger dimension!



# Pipe dimensions of the connecting pipe

## Recommended pipe dimension of the connecting pipe

Number of collectors	Length of pipe F + BF			
	from 40 m to 45 m	from 45 m to 50 m	from 50 m to 55 m	from 55 m to 60 m
2 coll. - 132 L/h	18 x 1	18 x 1	18 x 1	18 x 1
3 coll. - 198 L/h	18 x 1	18 x 1	18 x 1	22 x 1
4 coll. - 264 L/h	22 x 1	22 x 1	22 x 1	22 x 1
5 coll. - 330 L/h	22 x 1	22 x 1	22 x 1	22 x 1
6 coll. - 396 L/h	22 x 1	22 x 1	22 x 1	22 x 1
7 coll. - 462 L/h	28 x 1,5	28 x 1,5	28 x 1,5	28 x 1,5
8 coll. - 528 L/h	28 x 1,5	28 x 1,5	28 x 1,5	28 x 1,5
9 coll. - 594 L/h	28 x 1,5	28 x 1,5	28 x 1,5	28 x 1,5
10 coll. - 660 L/h	28 x 1,5	28 x 1,5	28 x 1,5	28 x 1,5
11 coll. - 726 L/h	28 x 1,5	28 x 1,5	28 x 1,5	28 x 1,5
12 coll. - 792 L/h	28 x 1,5	35 x 1,5	35 x 1,5	35 x 1,5
13 coll. - 858 L/h	35 x 1,5	35 x 1,5	35 x 1,5	35 x 1,5
14 coll. - 924 L/h	35 x 1,5	35 x 1,5	35 x 1,5	35 x 1,5
15 coll. - 990 L/h	35 x 1,5	35 x 1,5	35 x 1,5	35 x 1,5

The data refer to the plain tube. With corrugated pipe we recommend to choose the larger dimension!



# Initial operation

## Initial operation

After installing the other components such as flow pipe, return pipe, insulation, pump group, expansion tank and controller, the installation can be put into service. Perform a leak test and complete the commissioning log.

Protect the collectors from direct sunlight if the filling of the installation is not carried out within five days after completion of the assembly.

## Inspections within the first two weeks of operation

- bleeding the solar circle
- control system pressure

## Instructions for the operation of the installation

Carry out changes to the scheme and other system components only after consultation and with inputs from your specialized partner.

Ensure that an appropriate safety valve is mounted whose opening pressure is not exceeding the maximal operating pressure of the collectors.

Furthermore, do not install shut-off valves which may affect or prevent the function of the safety valve.

Carry out maintenance and inspections with appropriate caution.

Certain components may reach temperatures up to 200 °C. There is a risk of burns.

It is absolutely necessary to make sure that the back flow temperature is never lower than the ambient temperature. If necessary, take appropriate measures (e. g. increase of back flow temperature to at least 30 °C).

## Regular inspections

Solar systems should be reviewed at intervals to be determined in addition to the function control by the operator.

The maintenance intervals of the system will be defined during commissioning.

An annual review is recommended. The following components must be checked for proper function (if installed):

- solar collectors
- solar circle
- heat transfer liquid
- solar storage
- solar regulator incl. circulation pump
- supplementary heating system
- expansion tank

## Unscheduled maintenance

Depending on the location of the installation, environmental influences may cause soiling on the collector glass (dust, pollen etc.). If necessary, clean the glass exclusively with clear water to ensure optimal light transmission.

If it is necessary to free the system from snow or ice, only use non-metal cleaning equipment such as brooms with due care.

Only walk on roof areas in compliance with all safety aspects.

Heavy condensation may occur on the interior side of the glass when defrosting while the collectors are covered with snow. It is absolutely necessary to free the collectors from snow to avoid damages due to humidity.

# Initial operation

Commissioning report									
System operator					Installer				
Street					Street				
Postcode/City					Postcode/City				
Material	Product	Type	Special feature	Material	Date of assembly				
tick accordingly	(description)	(Serial N°)	Net surface						
Flat plate collector					Date of commissioning				
Piping									
Heat exchanger					Type of installation				
Storage 1			Content lit.		Roof-integrated				
Storage 2			Content lit.		Roof-mounted				
Solar regulation					Console				
Expansion tank			Content lit.	Safety valve	bar				
DrainMaster			Content lit.						
Collector adjustment south 0°, west +90°; east -90°)				Setting angle of collectors					
Height				Meter					
Setting value (Control value=*)		Type /Programme		Maximum temperature		Temperature difference F-BF		Hysteresis	
Consumer 1* = e.g. water for domestic use				°C		K		K	
Consumer 2* = e.g. 1. buffer store				°C		K		K	
Consumer 3* = e.g. 2. buffer store				°C		K		K	
Consumer 4* = e.g. swimming pool				°C		K		K	
Maximum temperatur of collector		°C		Solar protective function from °C		Yes		No	
Operating pressure at		bar		System pressure expansion tank		Debit: bar		Actual value:	
Heat transfer medium									
Visual check	normal/pink		brown		black		murky		
Type			Minimum value	Actual value	System		rinsed filtered bleded		
Liquid capacity	pH-value								
Ratio	Frost protection								
General system checkpoints									
Collector clean			ok	Pumps tested on functionality			ok		
Stable collector fastening			ok	Temperature sensor shows realistic values			ok		
Collector not steamed up (interior)			ok	Grounding of the system			ok		
Non-return valve (not for DrainM.)			ok	Mixer - water for domestic use			ok		
Operating hours	Pump 1		h	Pump 2		h	Calorimeter /kWh		
<b>Remarks:</b>									



# Initial operation

Schematic drawing of the system construction and piping scheme:



# Appendix

## **Important to observe**

Any guarantee and warranty for collectors as well as for resulting damages on the system or building expires due to unauthorized changes on the collectors and the accessories.

There is no guarantee or warranty due to optical or technical reduction or defects on the collector resulting from external influences, forasmuch as these influences are not part of the supplier's sphere or influence and they are not explicitly known before execution.

**STI Solar-Technologie-International GmbH**

Seiferitzer Allee 14

D-08393 Meerane

Tel 0049 3764 795610

[info@sti-solar.de](mailto:info@sti-solar.de)

[sti-solar.de](http://sti-solar.de)