

CANADIAN SOLAR INC.

Global Headquarters:

545 Speedvale Avenue, West Guelph, Ontario N1K 1E6, Canada

Tel: +1 519 837 1881

Sales Inquiries Email: sales.ca@canadiansolar.com

Technical Inquiries Email: service.ca@canadiansolar.com

CANADIAN SOLAR (USA) , INC.

North America Headquarters:

3000 Oak Road, Ste 400, Walnut Creek, CA 94596

Tel: +1 888 998 7739

Sales Inquiries Email: sales.us@canadiansolar.com

Technical Inquiries Email: service.ca@canadiansolar.com

Europe, Middle East & Africa

Canadian Solar EMEA GmbH

Landsberger Strasse 94, 80339 Munich, Germany

Tel.: +49 89 5199689 0

E-mail: service.emea@canadiansolar.com

This manual is subject to change without prior notification. Copyright is reserved. Duplication of any part of this issue is prohibited without written permission.



CSI Three Phase Inverter

(100-125kW) **Installation and Operation Manual**

Ver 1.0

CANADIAN SOLAR INC.

- Product specifications are subject to change without notice. Every attempt has been made to make this document complete, accurate and up-to-date. Individuals reviewing this document and installers or service personnel are cautioned, however, that Canadian Solar reserves the right to make changes without notice and shall not be responsible for any damages, including indirect, incidental or consequential damages caused by reliance on the material presented including, but not limited to, omissions, typographical errors, arithmetical errors or listing errors in the material provided in this document.
- Canadian Solar accepts no liability for customers' failure to comply with the instructions for correct installation and will not be held responsible for upstream or downstream systems Canadian Solar equipment has supplied.
- The customer is fully liable for any modifications made to the system; therefore, any hardware or software modification, manipulation, or alteration not expressly approved by the manufacturer shall result in the immediate cancellation of the warranty.
- Given the countless possible system configurations and installation environments, it is essential to verify adherence to the following:
 - There is sufficient space suitable for housing the equipment.
 - Airborne noise produced depending on the environment.
 - Potential flammability hazards.
- Canadian Solar will not be held liable for defects or malfunctions arising from:
 - Improper use of the equipment.
 - Deterioration resulting from transportation or particular environmental conditions.
 - Performing maintenance incorrectly or not at all.
 - Tampering or unsafe repairs.
 - Use or installation by unqualified persons.
- This product contains lethal voltages and should be installed by qualified electrical or service personnel having experience with lethal voltages.

1. Introduction	4	6.4.1 Lock screen	38
1.1 Product Description	4	6.5 Settings	38
1.2 Unpacking and storage	5	6.5.1 Set Time	38
1.2.1 Storage	6	6.5.2 Set Address	38
2. Safety instructions	7	6.6 Advanced Info - Technicians Only	39
2.1 Safety symbols	7	6.6.1 Alarm Message	39
2.2 General safety instructions	7	6.6.2 Running Message	39
2.3 Notice for use	8	6.6.3 Version	40
2.4 Protection Circuitry and Controls	8	6.6.4 Daily Energy	40
3. Installation	10	6.6.5 Monthly Energy	40
3.1 Environmental considerations	10	6.6.6 Yearly Energy	41
3.1.1 Select a location for the inverter	10	6.6.7 Daily Records	41
3.1.2 Other environmental considerations	11	6.6.8 Communication Data	41
3.2 Product handling	12	6.6.9 Warning Message	41
3.3 Mounting the Inverter	13	6.7 Advanced Settings - Technicians Only	42
3.3.1 Wall mounting	14	6.7.1 Selecting Standard	42
3.3.2 Rack mounting	15	6.7.2 Grid ON/OFF	43
3.4 Electrical Connections	17	6.7.3 Clear Energy	43
3.4.1 Grounding	18	6.7.4 Reset Password	44
3.4.2 Connect PV side of inverter	20	6.7.5 Power control	44
3.4.3 Connect grid side of inverter	23	6.7.6 Calibrate Energy	44
4. Communication & Monitoring	26	6.7.7 Special Settings	45
4.1 RS485 and Ethernet communication connection	26	6.7.8 STD Mode settings	45
4.1.1 RS485 communication	26	6.7.9 Restore Settings	45
4.1.2 Ethernet communication	29	6.7.10 HMI Update	46
5. Commissioning	30	6.7.11 External EPM Set	46
5.1 Selecting the appropriate grid standard	30	6.7.12 Restart HMI	46
5.1.1 Verifying grid standard for country of installation	30	6.7.13 Debug Parameter	47
5.2 Changing the grid standard	30	6.7.14 Fan Test	47
5.2.1 Procedure to set the grid standard	30	6.7.15 DSP Update	48
5.3 Setting a custom grid standard	31	6.7.16 Compensation Set	48
5.4 Preliminary checks	32	6.7.17 I/V Curve	49
5.4.1 DC Connections	32	7. Maintenance	50
5.4.2 AC Connections	32	7.1 Anti-PID Function	50
5.4.3 DC configuration	32	7.2 Fan Maintenance	51
5.4.4 AC configuration	34	7.3 Fuse Maintenance	52
6. Normal operation	35	7.4 Surge Protection Device Maintenance	53
6.1 Start-up procedure	35	8. Troubleshooting	54
6.2 Shutdown procedure	35	9. Specifications	56
6.3 Main Menu	36	10. Appendices	58
6.4 Information	36	11. Installation and commissioning checklist	60

1. Introduction



1.1 Product Description

Canadian Solar Three phase Inverters convert DC power from the photovoltaic(PV) array into alternating current(AC) power that can satisfy local loads as well as feed the power distribution grid.

This manual covers the three phase inverter model listed below:

CSI-100KTL-GI-E, CSI-125KTL-GI-E

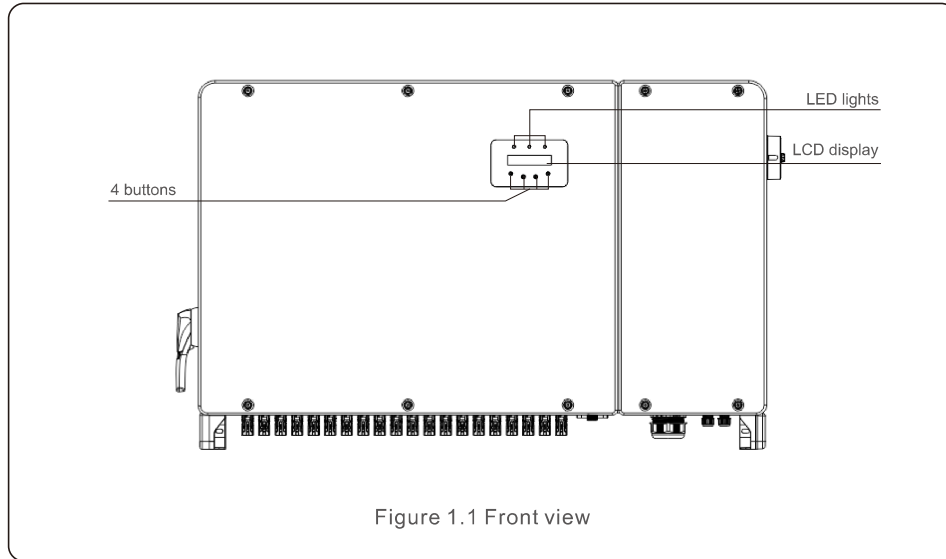

Figure 1.1 Front view

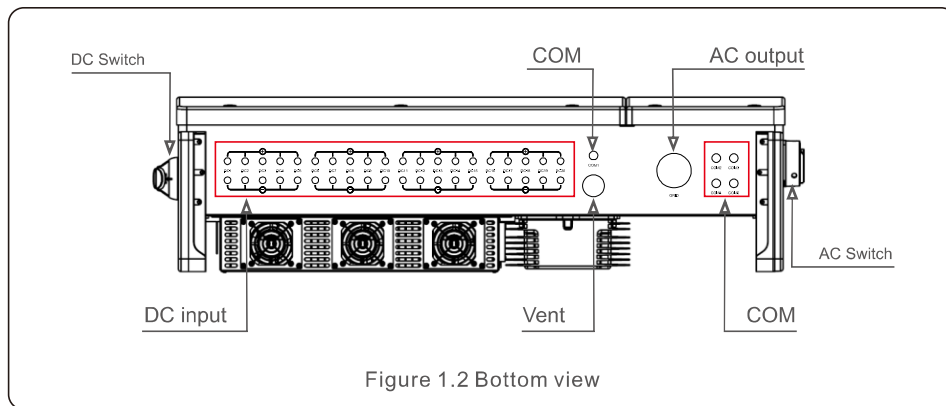

Figure 1.2 Bottom view



1. Introduction

1.2 Unpacking and storage

The inverter ships with all accessories in one carton.

When unpacking, please verify all the parts listed below are included:

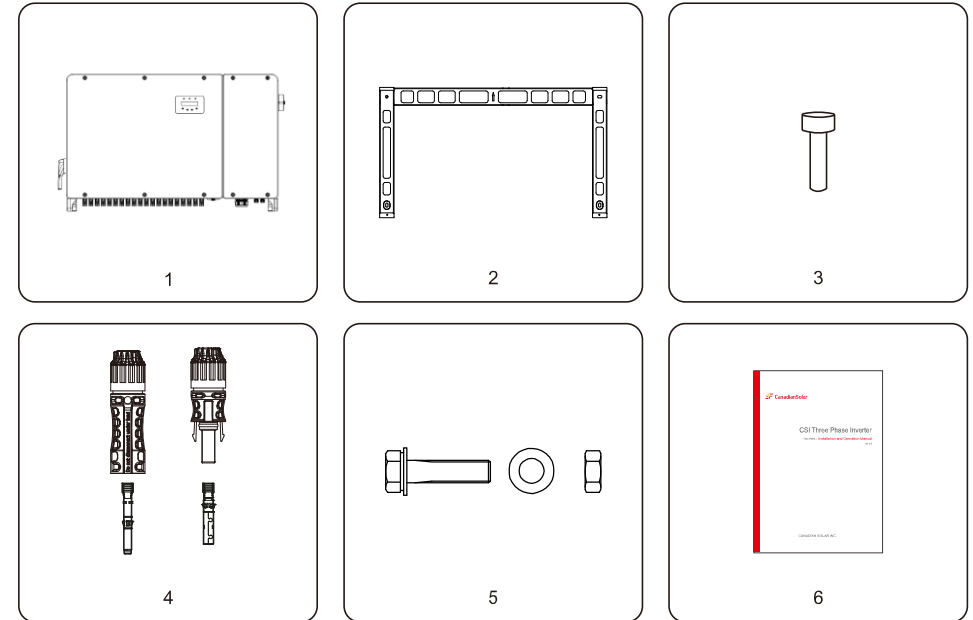

Part #	Description	Number	Remarks
1	Inverter	1	
2	Back plate	1	
3	Fastening screw	2	Hexagon bolt M6*12
4	DC connector	16/20	100K *16, 125K *20
5-1	Hexagon bolt	4	Hexagon bolt M10*40
5-2	Hexagonal nut	4	
5-3	Washer	4	
6	User manual	1	

Inverter packing list

1.2.1 Storage

If the inverter is not installed immediately, storage instructions and environmental conditions are below:

- Use the original box to repackage the inverter, seal with adhesive tape with the desiccant inside the box.
- Store the inverter in a clean and dry place, free of dust and dirt. The storage temperature must be between -40 and 158 F (-40 - 70C) and humidity should be between 0 to 100%, non-condensing.
- Do not stack more than two (2) inverters high on a single pallet. Do not stack more than 2 pallets high.
- Keep the box(es) away from corrosive materials to avoid damage to the inverter enclosure.
- Inspect the packaging regularly. If packing is damaged (wet, pest damages, etc.), repackage the inverter immediately.
- Store inverters on a flat, hard surface -- not inclined or upside down.
- After 100 days of storage, the inverter and carton must be inspected for physical damage before installing. If stored for more than 1 year, the inverter needs to be fully examined and tested by qualified service or electrical personnel before using.
- Restarting after a long period of non-use requires the equipment be inspected and, in some cases, the removal of oxidation and dust that has settled inside the equipment will be required.



Figure 1.3

Improper use may result in electric shock hazards or burns. This product manual contains important instructions that are required to be followed during installation and maintenance. Please read these instructions carefully before use and keep them in an easily locatable place for future reference.

2.1 Safety symbols

Safety symbols used in this manual, which highlight potential safety risks and important safety information, are listed below:



WARNING

Symbol indicates important safety instructions, which if not correctly followed, could result in serious injury or death.



NOTE

Symbol indicates important safety instructions, which if not correctly followed, could result in damage to or the destruction of the inverter.



CAUTION, RISK OF ELECTRIC SHOCK

Symbol indicates important safety instructions, which if not correctly followed, could result in electric shock



CAUTION, HOT SURFACE

Symbol indicates safety instructions, which if not correctly followed, could result in burns.

2.2 General safety instructions



WARNING

Do not connect PV array positive (+) or negative (-) to ground – doing so could cause serious damage to the inverter.



WARNING

Electrical installations must be done in accordance with local and national electrical safety standards.



WARNING

To reduce the risk of fire, branch circuit over-current protective devices (OCPD) are required for circuits connected to the Inverter.



CAUTION

The PV array (solar panels) supplies a DC voltage when exposed to light.



CAUTION

Risk of electric shock from energy stored in the inverter's capacitors. Do not remove cover until five (5) minutes after disconnecting all sources of supply have passed, and this can only be done by a service technician. The warranty may be voided if any unauthorized removal of cover occurs.



CAUTION

The inverter's surface temperature can reach up to 75°C (167°F). To avoid risk of burns, do not touch the surface when the inverter is operating. Inverter must be installed out of the reach of children.



WARNING

The inverter can only accept a PV array as a DC input. Using any other type of DC source could damage the inverter.

2.3 Notice for use

The inverter has been constructed according to applicable safety and technical guidelines.

Use the inverter in installations that meet the following requirements ONLY:

- 1). The inverter must be permanently installed.
- 2). The electrical installation must meet all the applicable regulations and standards.
- 3). The inverter must be installed according to the instructions stated in this manual.
- 4). The system design must meet inverter specifications.

To start-up the inverter, the Grid Supply Main Switch (AC) must be turned on, BEFORE the DC Switch is turned on. To stop the inverter, the Grid Supply Main Switch (AC) must be turned off before the DC Switch is turned off.

2.4 Protection Circuitry and Controls

To meet relevant codes and standards, the Canadian Solar three phase inverter line is equipped with protective circuitry and controls.

Anti-Islanding Protection:

Islanding is a condition where the inverter continues to produce power even when the grid is not present. Circuitry, along with firmware, has been designed to determine if the grid is present by adjusting the output frequency of the inverter. In the case of a 60Hz resonant system where the inverter is partially isolated from the grid, the inverter programming can detect if there is a resonant condition or if the grid is actually present. It can also differentiate between inverters operating in parallel and the grid.

3.1 Environmental considerations

3.1.1 Select a location for the inverter

When selecting a location for the inverter, consider the following:

- The temperature of the inverter heat-sink can reach 167°F (75C).
- The inverter is designed to work in an ambient temperature range between -13°F to 140°F (-25 - 60C).
- If multiple inverters are installed on site, a minimum clearance of 500mm should be kept between each inverter and all other mounted equipment. The bottom of the inverter should be at least 500mm above of the ground or floor (see Figure 3.1).
- The LED status indicator lights and the LCD located on the inverter's front panel should not be blocked.
- Adequate ventilation must be present if the inverter is to be installed in a confined space.

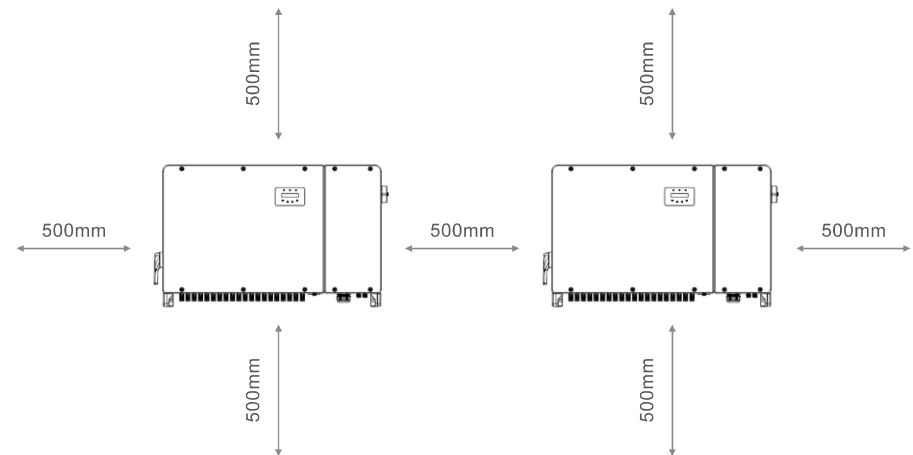

Figure 3.1 Distances required between inverters



NOTE

Nothing should be stored on or placed against the inverter.

3.1.1.1 Examples of correct and incorrect installations

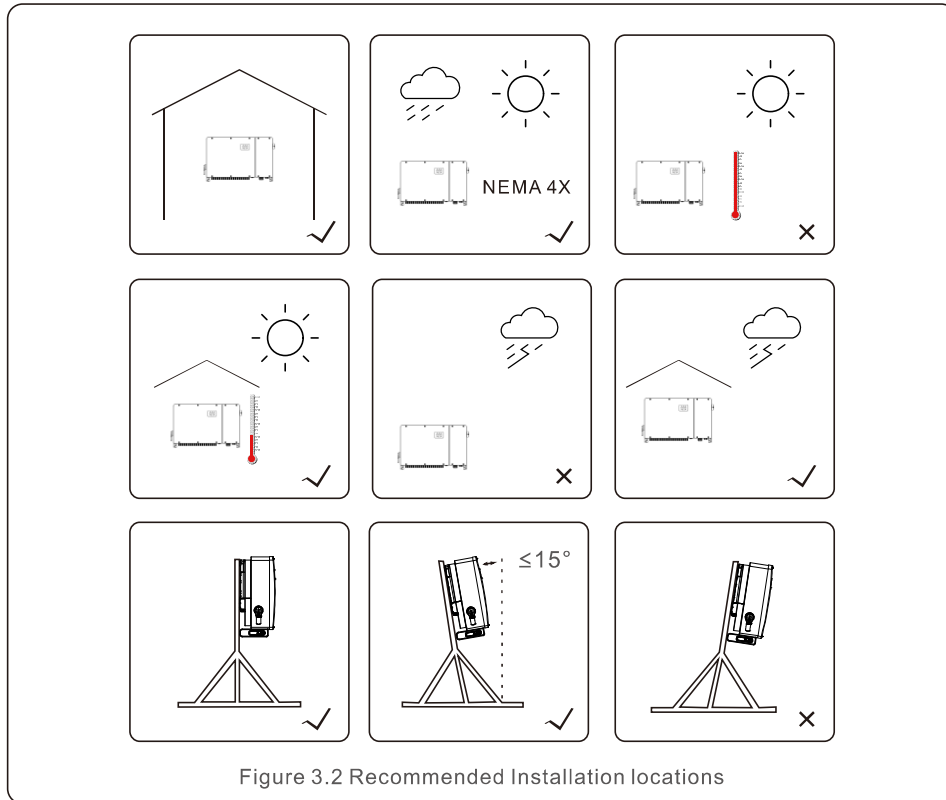

Figure 3.2 Recommended Installation locations

3.1.2 Other environmental considerations

3.1.2.1 Consult technical data

Consult the specifications section (section 9) for additional environmental conditions (protection rating, temperature, humidity, altitude, etc.).

3.1.2.2 Vertical wall installation

This model of Canadian Solar inverter should be mounted vertically (90 degrees or backwards 15 degrees) .

3.1.2.3 Avoiding direct sunlight

Installation of the inverter in a location exposed to direct sunlight should be avoided.

Direct exposure to sunlight could cause:

- Power output limitation (with a resulting decreased energy production by the system).
- Premature wear of the electrical/electromechanical components.
- Premature wear of the mechanical components (gaskets) and user interface.

3.1.2.4 Air circulation

Do not install in small, closed rooms where air cannot freely circulate. To prevent overheating, always ensure that the air flow around the inverter is not blocked.

3.1.2.5 Flammable substances

Do not install near flammable substances. Maintain a minimum distance of three (3) meters (10 feet) from such substances.

3.1.2.6 Living area

Do not install in a living area where the prolonged presence of people or animals is expected. Depending on where the inverter is installed (for example: the type of surface around the inverter, the general properties of the room, etc.) and the quality of the electricity supply, the sound level from the inverter can be quite high.

3.2 Product handling

Please review the instruction below for handling the inverter:

1. The red circles below denote cutouts on the product package.

Push in the cutouts to form handles for moving the inverter (see Figure 3.3).

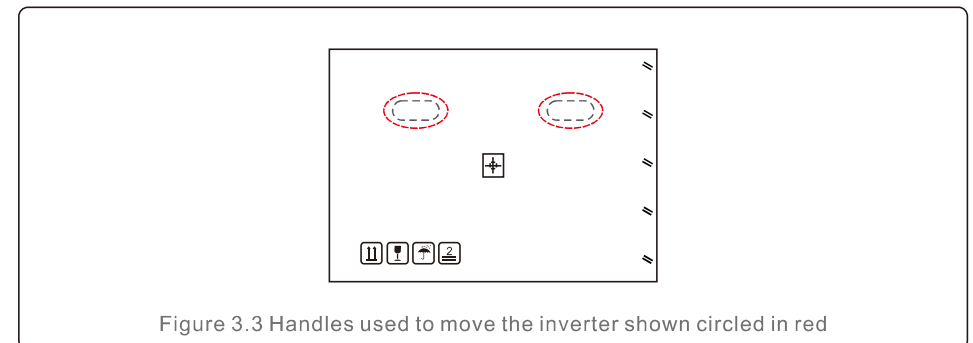

Figure 3.3 Handles used to move the inverter shown circled in red

2. Two people are required to remove the inverter from the shipping box. Use the handles integrated into the heat sink to remove the inverter from the carton (see Figure 3.4).

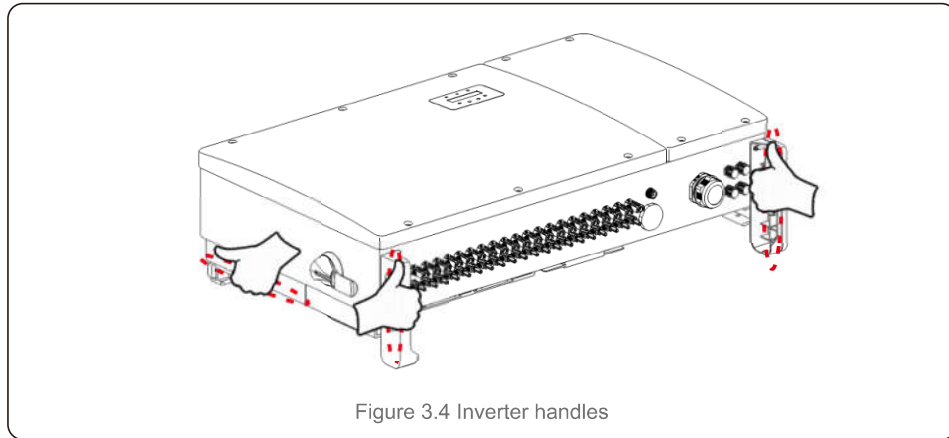

Figure 3.4 Inverter handles



WARNING

Due to the weight of the inverter, contusions or bone fractures could occur when incorrectly lifting and mounting the inverter. When mounting the inverter, take the weight of the inverter into consideration. Use a suitable lifting technique when mounting.

3.3 Mounting the Inverter

The inverter can be mounted to the wall or metal array racking. The mounting holes should be consistent with the size of the bracket or the dimensions shown in Figure 3.5.

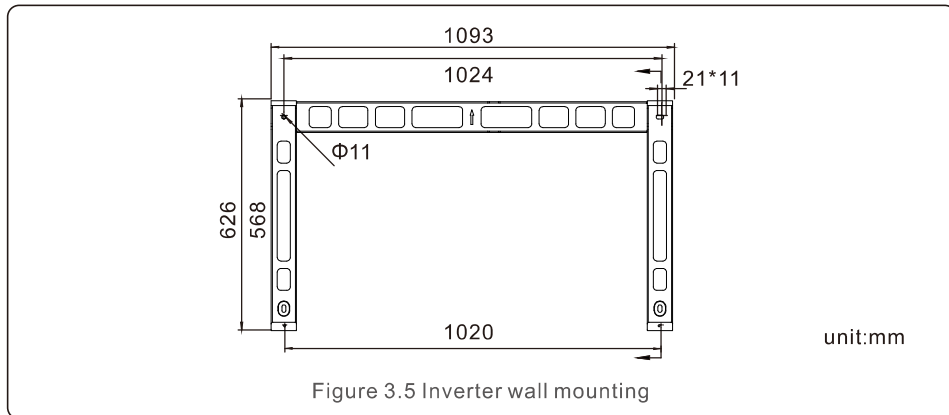

Figure 3.5 Inverter wall mounting

unit:mm

3.3.1 Wall mounting

Refer to figure 3.6 and figure 3.7 Inverter shall be mounted vertically.

The steps to mount the inverter are listed below.

1. Refer to Figure 3.6, drill holes for mounting screws based on the hole diameter of bracket using a precision drill keeping the drill perpendicular to the wall. Max depth is 90mm.
2. Make sure the bracket is horizontal. And the mounting holes (in Figure 3.6) are marked correctly. Drill the holes into wall at your marks.
3. Use the suitable mounting screws to attach the bracket on the wall.

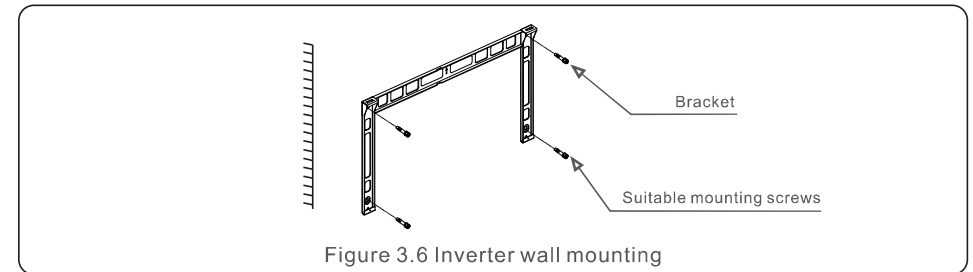

Figure 3.6 Inverter wall mounting

4. Lift the inverter and hang it on the bracket, and then slide down to make sure they match perfectly.

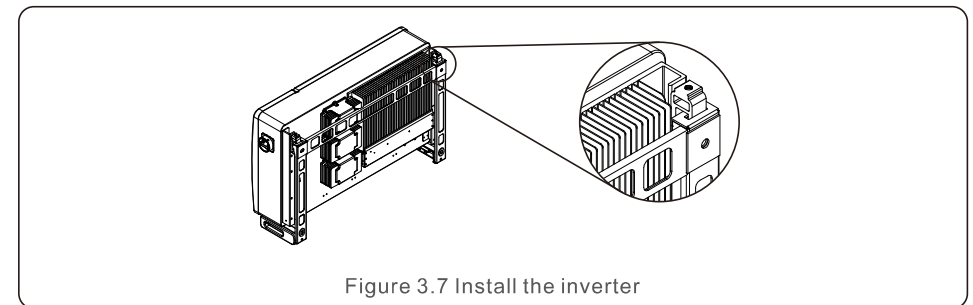

Figure 3.7 Install the inverter

5. Use screws in the packaging to fix the inverter to the mount bracket.

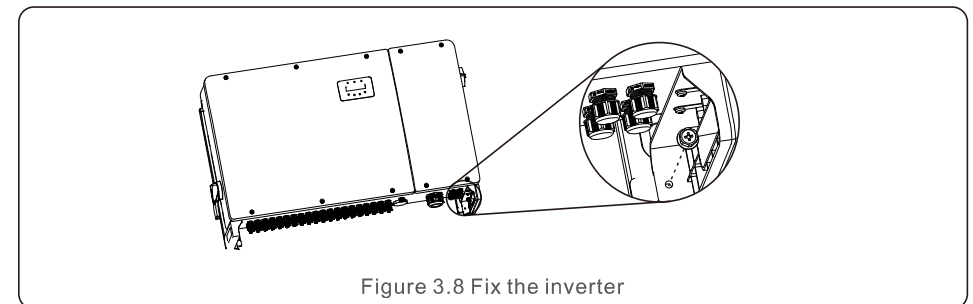

Figure 3.8 Fix the inverter

3.3.2 Rack mounting

The steps to mounted to the rack are listed below:

1. Select a location for the inverter

- With an NEMA4X protection rating, the inverter can be installed both outdoors and indoors.
- When the inverter is running, the temperature of the chassis and heat sink will be higher, Do not install the inverter in a location that you accidentally touch.
- Do not install the inverter in a place where it is stored in a flammable or explosive material.

2. Installation angle

Please install the inverter vertically. If the inverter cannot be mounted vertically, it may be tilted backward to 15 degrees from vertical.

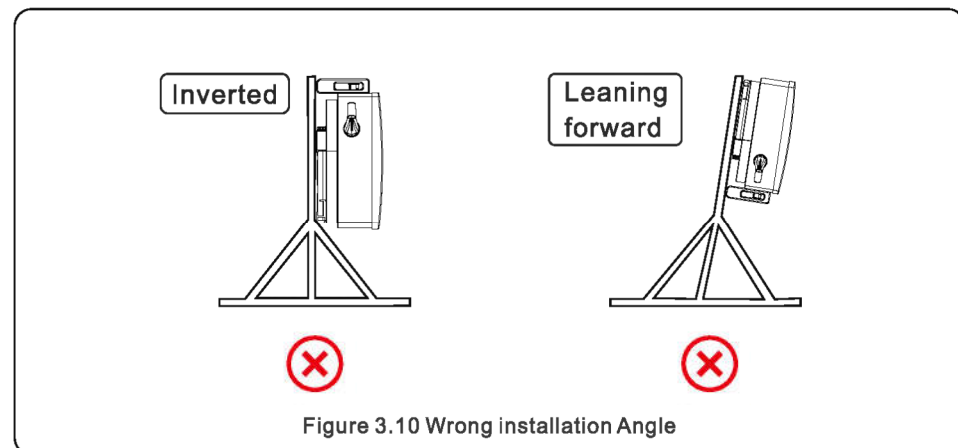
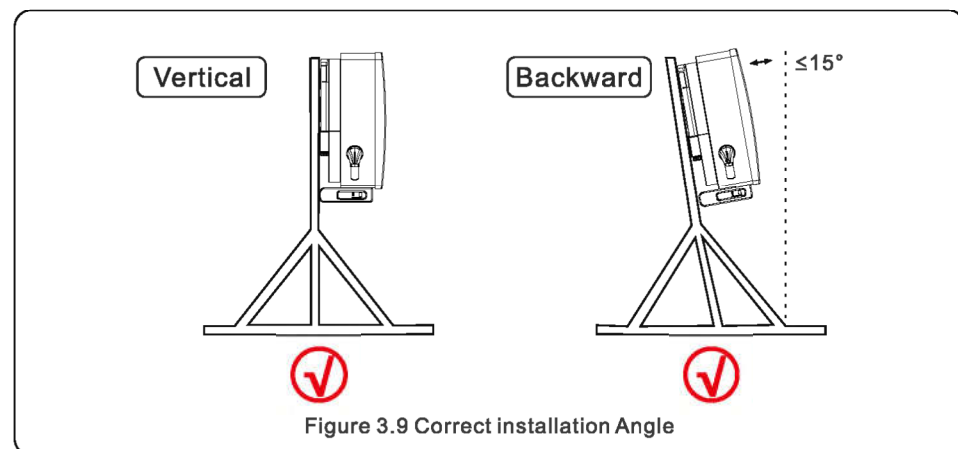

3. Install mounting plate

- 1) Remove the bracket and fasteners from the packaging. Mark the position for hole, drilling according to the hole positions of the bracket.

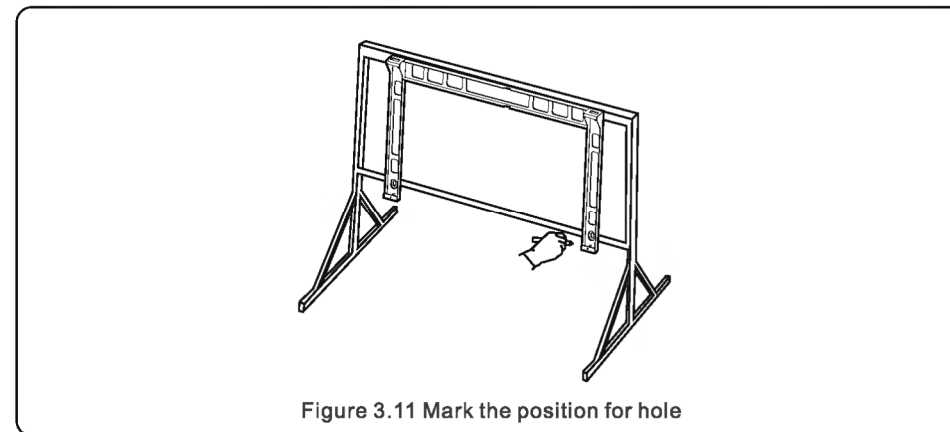

- 2) Drill the marked holes. It is recommended to apply anti-corrosive paint at the hole for corrosion protection.

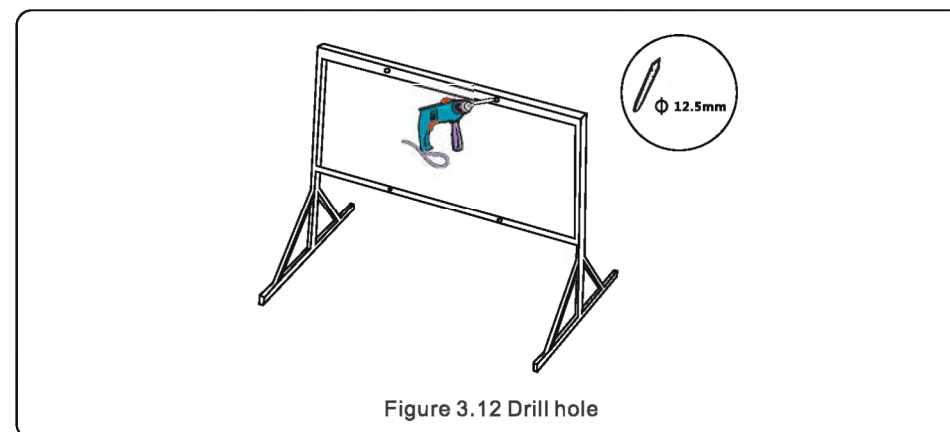

3) Align the mounting plate with the holes, Insert the combination bolt (M10X40) through the mounting plate into the hole. Secure the bracket to the metal frame firmly with the supplied fastener. Torque the nut to 36FT-LB (35NM).

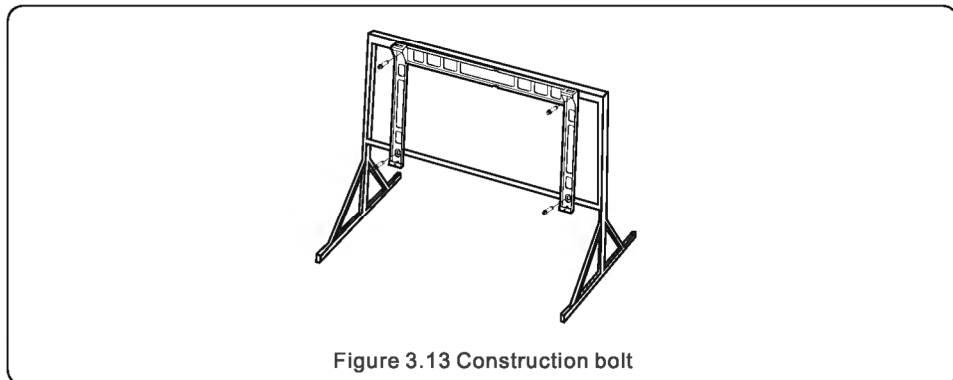

Figure 3.13 Construction bolt

4) Lift the inverter above the bracket and then slide down to make sure they match perfectly.

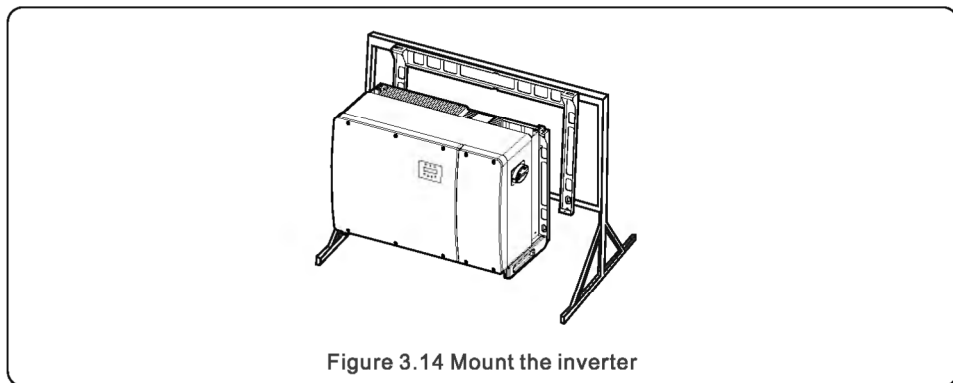

Figure 3.14 Mount the inverter

3.4 Electrical Connections

Inverter design uses PV style quick-connect terminal. The top cover needn't be opened during DC electrical connection. The labels located the bottom of the inverter are described below in table 3.1. All electrical connections are suitable for local or national standard.

Parts	Connection	Cable size	Torque
DC terminal	PV strings	12-10 AWG	NA
Ground terminal	AC ground	3-1 AWG	10-20N.m
Grid terminal	Grid	2-4/0 AWG	10-12N.m
RS-485 terminal	Communication cable	22-12 AWG	0.6N.m
RJ45 terminal	Communication cable	Network cable	NA
COM terminal	Wi-Fi/Cellular stick	NA	NA
DC surge protection device	NA	NA	NA

Table 3.1 Electrical connection symbols

The electrical connection of the inverter must follow the steps listed below:

1. Switch the Grid Supply Main Switch (AC) OFF.
2. Switch the DC Isolator OFF.
3. Connect the inverter to the grid.
4. Assemble PV connector and connect to the Inverter.

3.4.1 Grounding

To effectively protect the inverter, two grounding methods must be performed.
 Connect the AC grounding cable (Please refer to section 3.4.3)
 Connect the external grounding terminal.

To connect the grounding terminal on the heat sink, please follow the steps below:

- 1) Prepare the grounding cable: recommend to use the outdoor copper-core cable. The grounding wire should be at least half size of the hot wires.
- 2) Prepare OT terminals: M10.



Important:

For multiple inverters in parallel, all inverters should be connected to the same ground point to eliminate the possibility of a voltage potential existing between inverter grounds.

- 3) Strip the ground cable insulation to a suitable length (see Figure 3.15).

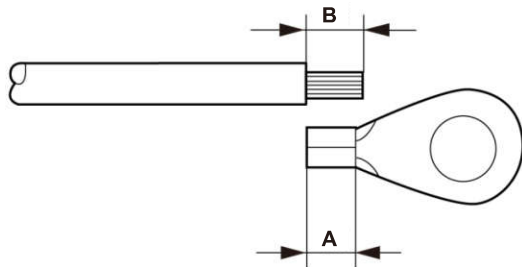

Figure 3.15 Suitable length



Important:

B (insulation stripping length) is 2mm~3mm longer than A (OT cable terminal crimping area) 2mm~3mm.

- 4) Insert the stripped wire into the OT terminal crimping area and use the hydraulic clamp to crimp the terminal to the wire (see Figure 3.16).

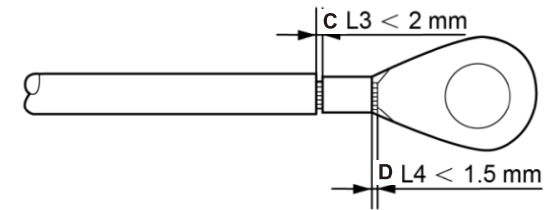

Figure 3.16 Strip wire



Important:

After crimping the terminal to the wire, inspect the connection to ensure the terminal is solidly crimped to the wire.

- 5) Remove the screw from the heat sink ground point.
- 6) Connect the grounding cable to the grounding point on the heat sink, and tighten the grounding screw, Torque is 6-8Nm (see figure 3.17).

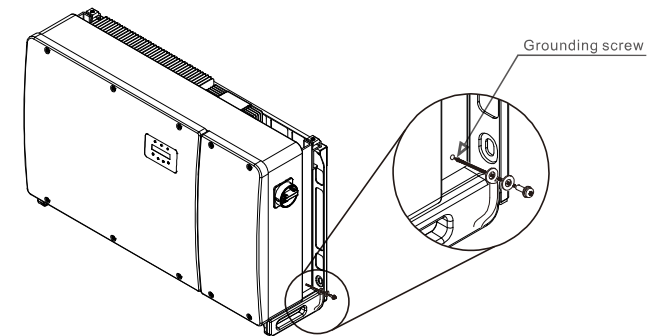

Figure 3.17 Fixed cable



Important:

For improving anti-corrosion performance, after ground cable installed, apply silicone or paint.

3.4.2 Connect PV side of inverter



WARNING

Before connecting the inverter, make sure the PV array open circuit voltage is within the limit of the inverter. Otherwise, the inverter could be damaged.

Maximum 1500Vdc for CSI-100KTL-GI-E, CSI-125KTL-GI-E



WARNING

DO NOT connect the PV array positive or PV array negative cable to ground. This can cause serious damage to the inverter!



WARNING

MAKE SURE the polarity of the PV array output conductors matches the DC- and DC+ terminal labels before connecting these conductors to the terminals of the inverter.



Please use appropriate DC cable for PV system.

Please see table 3.1 for acceptable wire size for DC connections. Wire must be copper only. The steps to assemble the DC connectors are listed as follows:

1. Strip off the DC wire for about 7mm, Disassemble the connector cap nut. (see Figure 3.18)
2. Insert the wire into the connector cap nut and contact pin. (see Figure 3.19)
3. Crimp the contact pin to the wire using a proper wire crimper. (see Figure 3.20)
4. Insert metal connector into top of connector, and tighten nut with torque 3-4 Nm (see figure 3.21).
5. Measure PV voltage of DC input with multimeter, verify DC input cable polarity (see figure 3.22), and ensure each string voltage is in range of inverter operation. Connect DC connector with inverter until hearing a slight clicking sound indicating successful connection. (see figure 3.23)



Figure 3.18 Disassemble the Connector Cap nut

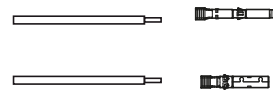

Figure 3.19 Insert the Wire into the Connector Cap nut and contact pin

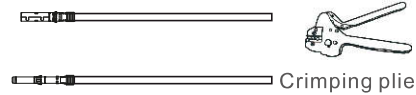

Figure 3.20 Crimp the contact pin to the wire

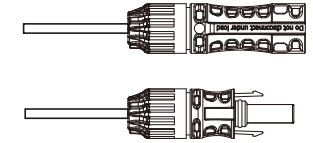

Figure 3.21 Connector with Cap nut Screwed on

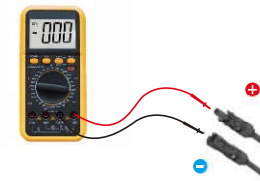

Figure 3.22 Multimeter measurement

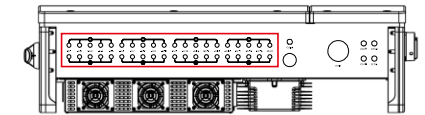

Figure 3.23 Connect the DC Connectors to the Inverter



WARNING:

If a DC input is connected in reverse polarity, please not operate DC switch, and remove DC wires to avoid inverter damage. Damage caused by this reason isn't covered by warranty.

Solution: Wait until sun irradiance is low and PV current is below 0.5 A (mostly in evening), then put DC switch in "off" position, remove "+", "-" connectors to change polarity and reconnect wires.

Requirements for the PV modules per MPPT input:

- All PV modules must be of the same type and power rating.
- All PV modules must be aligned and tilted identically.
- The open-circuit voltage of the PV array must never exceed the maximum input voltage of the inverter, even at the coldest expected temperature. (see Section 9 "Specifications" for input current and voltage requirements)
- Each string connected to a single MPPT must consist of the same number of series-connected PV modules.

3.4.2.1 DC connection high voltage danger notice



CAUTION
RISK OF ELECTRIC SHOCK

Do not touch an energized DC conductor. There are high voltages present when PV modules are exposed to light causing a risk of death due to an electric shock from touching a DC conductor!

Only connect the DC cables from the PV module to the inverter as described in this manual.



CAUTION
POTENTIAL DAMAGE TO THE INVERTER DUE TO OVERVOLTAGE

The DC input voltage of the PV modules must not exceed the maximum rating of the inverter. (see Section 9 “Specifications”)

Check the polarity and the open-circuit voltage of the PV strings before connecting the DC cables to the inverter.

Confirm proper string length and voltage range before connecting DC cable to the inverter.

3.4.2.2 Recommended fusing section for each channel or connection

Each DC string should be directly connected to the inverter.



Figure 3.24 Fuse holders

The sizing of the string fuses must take into account the two following conditions:

- 1). The nominal current rating of the selected fuse must not exceed the maximum fuse rating of the PV panels. Please refer to the applicable specifications for this value.
- 2). The fuse rating is determined based on the PV panel string current and on the sizing guidelines provided by the panel manufacturer or the local electrical code. In addition, the maximum fuse rating must not exceed the maximum input current of the inverter.

3.4.3 Connect grid side of inverter



WARNING
An over-current protection device must be used between the inverter and the grid.

- 1). Connect the three (3) AC conductors to the three (3) AC terminals marked “L1”, “L2” and “L3”. Refer to local code and voltage drop tables to determine the appropriate wire size and type.
- 2). Connect the grounding conductor to the terminal marked “PE” (protective earth, the ground terminal).

Over-Current Protection Device (OCPD) for the AC side

To protect the inverter’s AC connection line, we recommend installing a device for protection against over-current and leakage, with the following characteristics noted in Table 3.2:



NOTE
Use AL-CU transfer (bi-metallic) terminal or anti-oxidant grease with aluminum cables and terminals.

Inverter	Rated voltage(V)	Rated output current (Amps)	Current for protection device (A)
CSI-100KTL-GI-E	600	96	125
CSI-125KTL-GI-E	600	120	150

Table 3.2 Rating of grid OCPD

3.4.3.1 Connecting the inverter to the utility grid

All electrical installations must be carried out in accordance with the local standards and the National Electrical Code® ANSI/NFPA 70 or the Canadian Electrical Code® CSA C22.1. The AC and DC electric circuits are isolated from the enclosure. If required by section 250 of the National Electrical Code®, ANSI/NFPA 70, the installer is responsible for grounding the system.

The grid voltage must be within the permissible range. The exact operating range of the inverter is specified in Section 9 “Specifications”.

3.4.3.2 Wiring procedure



CAUTION

RISK OF ELECTRIC SHOCK. Prior to starting the wiring procedure, ensure that the three-pole circuit breaker is switched off and cannot be reconnected.



NOTE

Damage or destruction of the inverter's electronic components due to moisture and dust intrusion will occur if the enclosure opening is enlarged.



CAUTION

Risk of fire if two conductors are connected to one terminal. If a connection of two conductors to a terminal is made, a fire can occur. **NEVER CONNECT MORE THAN ONE CONDUCTOR PER TERMINAL.**



NOTE

Use M10 crimp terminals to connect to the inverter AC terminals.

The steps to assemble the AC grid terminals are listed as follows:

- 1) Strip the end of AC cable insulating jacket about 300mm then strip the end of each wire. (as shown in figure 3.25)

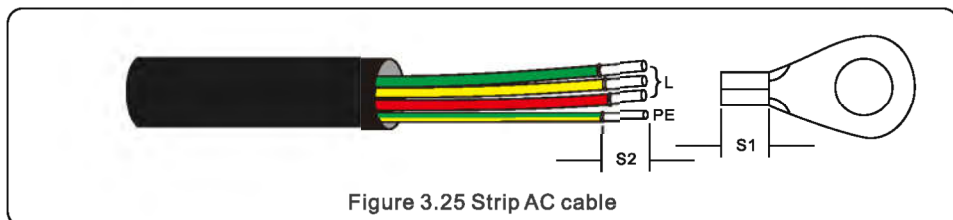

Figure 3.25 Strip AC cable



NOTE:

S2 (insulation stripping length) is 2mm-3mm longer than S1. (OT cable terminal crimping area)

- 2) Strip the insulation of the wire past the cable crimping area of the OT terminal, then use a hydraulic crimp tool to crimp the terminal. The crimped portion of the terminal must be insulated with heat shrinkable tube or insulating tape.
- 3) Leave the AC breaker disconnected to ensure it does not close unexpectedly.
- 4) Remove the 4 screws on the inverter junction box and remove the junction box cover (Figure 3.26).

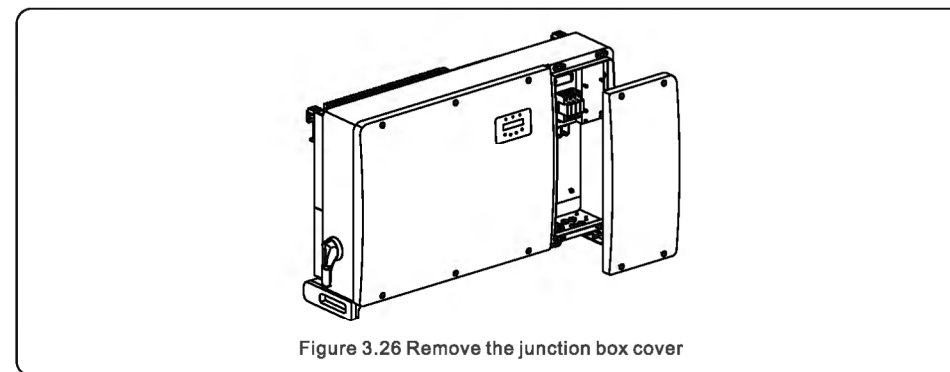

Figure 3.26 Remove the junction box cover

- 5) Insert the cable through the nut, sheath, and AC terminal cover. Connect the cable to the AC terminal block in turn, using a socket wrench. Tighten the screws on the terminal block. The torque is 10~20Nm (as shown in Figure 3.27).

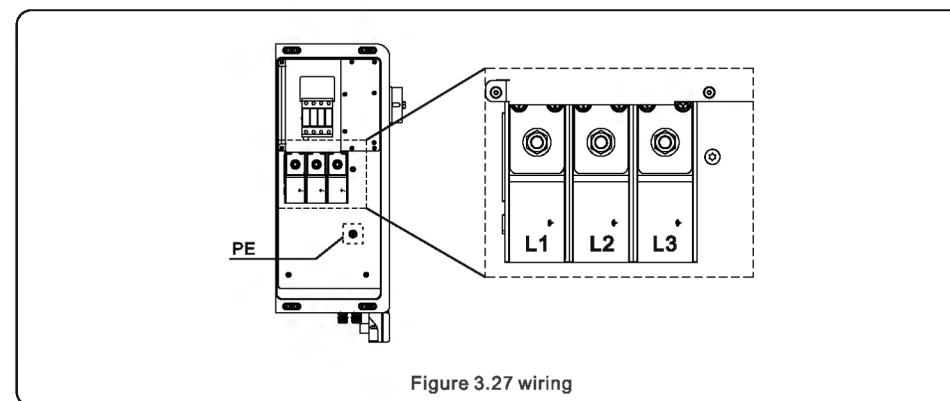
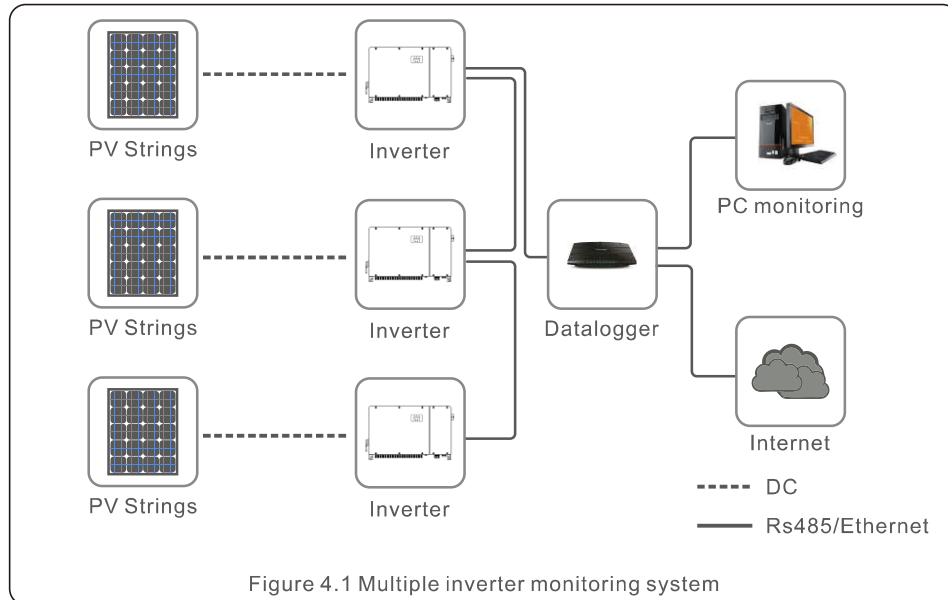

Figure 3.27 wiring

There are 5 communication terminals on Canadian Solar 125kW inverter. COM1 is a 4-pin connector reserved for WiFi/Cellular datalogger. COM2 and COM3 are RS485 connection between inverters and both RJ45 and Terminal block are provided for use. COM4 and COM5 are the Ethernet connection via RJ45.

Monitoring system for multiple inverters

Multiple inverters can be monitored through RS-485 and Ethernet daisy chain configuration.



4.1 RS485 and Ethernet communication connection

4.1.1 RS485 communication

RS-485 communication supports two connections methods: RJ45 connectors/ Terminal board

1. RS-485 communication through RJ45 connector

RJ45 port connection (See figure 4.2).

CAT 5E outdoor rated (cable outer diameter < 9mm, internal resistance $\leq 1.5 \Omega / 10m$) and shielded RJ45 connectors are recommended.



Figure 4.2 RJ45 port

Use the network wire stripper to strip the insulation layer off the communication cable. Using the standard wire sequence referenced in TIA/EIA 568B, separate the wires in the cable. Use a network cable tool to trim the wire. Flatten the wire in the order shown in figure 4.3.

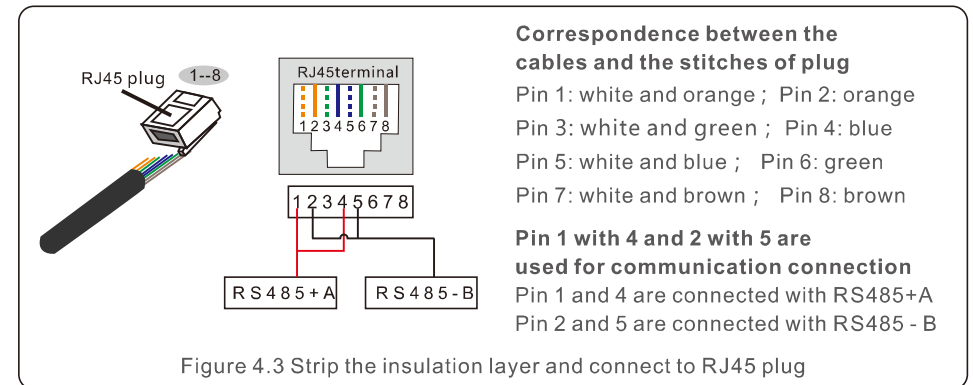

2. RS-485 communication through terminal board.

The cross sectional area of the cable wire for terminal board connection should be 0.2-1.5mm. The outer diameter of the cable may be 5mm-10mm.

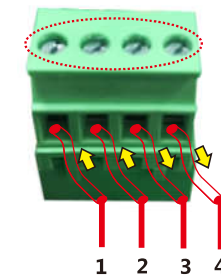

Figure 4.4

NO.	Port definition	Description
1	RS485A1 IN	RS485A1,RS485 differential signal+
2	RS485B1 IN	RS485B1,RS485 differential signal-
3	RS485A2 OUT	RS485A2,RS485 differential signal+
4	RS485B2 OUT	RS485B2,RS485 differential signal-

Table 4.1 Port definition

Connection of Terminal board.

- Strip the insulation and shield to a suitable length. Use diagram below as a guide. (in Figure 4.5).
- Remove the cap nut from the waterproof cable glands labeled at the bottom of the inverter. Remove the plug from the fitting. (in Figure 4.6).

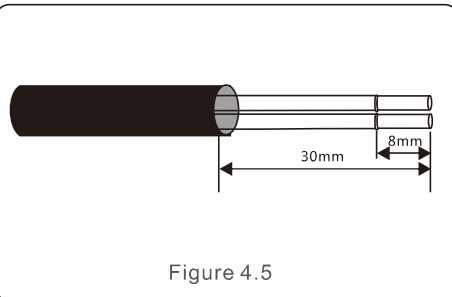

Figure 4.5

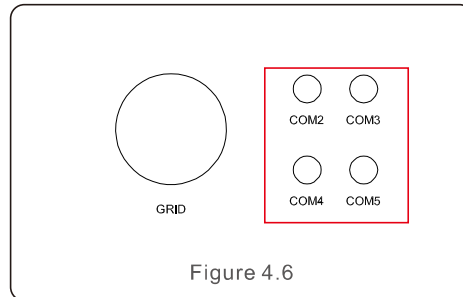

Figure 4.6

- Insert the cable through the cap nut for each port. COM2(RS485 IN) COM3(RS485 OUT).
- Pull down the terminal block on user interface board(See Figure 4.5).
- Firstly insert cable into terminal board, then tighten the screws (dotted area) clockwise with slotted screwdriver; if user need to pull out cable, screws rotates anticlockwise with slotted screwdriver(See Figure 4.5).
- Please insert terminal board into terminal block, then will be clamped automatically.

4.1.2 Ethernet communication

Using the RJ45 connectors to perform the ethernet communication.

Please refer to the figure 4.2.

CAT 5E outdoor rated (cable outer diameter<9mm, internal resistance $\leq 1.5\Omega / 10m$) and shielded RJ45 connectors are recommended.

If the product is connected to a local network through a router, the product will be assigned an IP address automatically, by the DHCP server. Daisy chain is required for multiple inverter communication through ethernet as shown below.

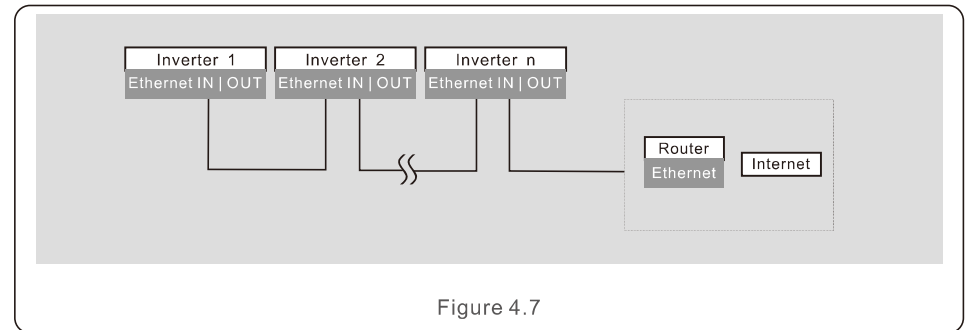

Figure 4.7

The connection must be done via a network cable. After daisy chain completed, please use the SN/ QR code on the board to register the system on the Ginlong monitoring website or APP .

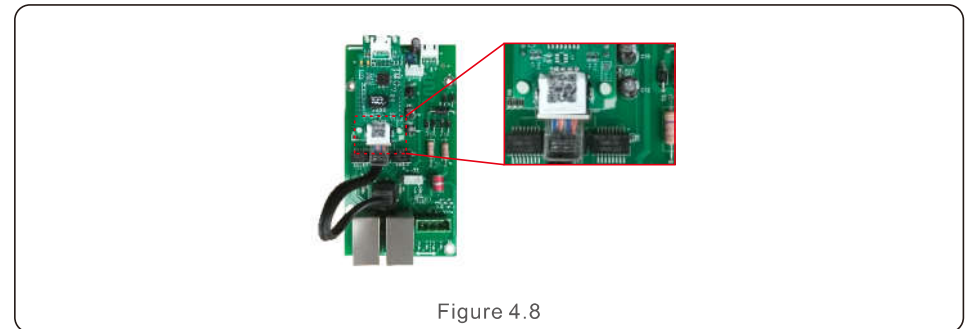

Figure 4.8

5.1 Selecting the appropriate grid standard

5.1.1 Verifying grid standard for country of installation

Canadian Solar inverters are used worldwide and feature preset standards for operating on any grid. Although the grid standard is set at the factory, it is essential the grid standard be verified for the country of installation before commissioning.

The menu for changing the grid standard or for creating a custom standard is accessible as described in Section 6.7 and below.



WARNING

Failure to set the correct grid standard could result in improper operation of the inverter, inverter damage or the inverter not operating at all.

5.2 Changing the grid standard

5.2.1 Procedure to set the grid standard



NOTE

This operation is for service technicians only. The inverter is customized according to the local grid standard before shipping. There should be no requirement to set the standard.



NOTE

The "User-Def" function can only be used by the service engineer. Changing the protection level must be approved by the local utility.

- 1). From the main screen on the display, select ENTER. There are 4 sub-menu options, use the UP/DOWN arrows to highlight ADVANCED SETTINGS. Press enter to select.

Figure 5.1

- 2). The screen will show that a password is required. The default password is "0010", press the DOWN key to move cursor, press the UP key to change the highlighted digit.

Figure 5.2

- 3). Use the UP/DOWN keys to highlight the SELECT STANDARD option. Press enter to select.

Figure 5.3

- 4). Select the grid standard for the country of installation.

Figure 5.4

Press the UP or DOWN key to select the standard. Press the ENTER key to confirm the setting. Press the ESC key to cancel changes and return to the previous menu.

5.3 Setting a custom grid standard



WARNING

- Failure to set the correct grid standard could result in improper operation of the inverter, inverter damage or the inverter not operating at all.
- Only certified personnel should set the grid standard.
- Only set the grid configuration that is approved by your location and national grid standards.

- 1). Please refer to section 6.7 "Advanced Settings" for procedures to create a custom grid configuration for User-Def menu option.

5.4 Preliminary checks



WARNING

High Voltage.

AC and DC measurements should be made only by qualified personnel.

5.4.1 DC Connections

Verify DC connections.

- 1). Lightly tug on each DC cable to ensure it is fully captured in the terminal.
- 2). Visually check for any stray strands that may not be inserted in the terminal.
- 3). Check to ensure the terminal screws are the correct torque.

5.4.2 AC Connections

Verify AC connections.

- 1). Lightly tug on each AC cable to ensure it is fully captured in the terminal.
- 2). Visually check for any stray strands that may not be inserted in the terminal.
- 3). Check to ensure the terminal screws are the correct torque.

5.4.3 DC configuration

Verify DC configuration by noting the number of panels in a string and the string voltage.

5.4.3.1 VOC and Polarity

Measure VOC, and check string polarity. Ensure both are correct and VOC is in specification.

5.4.3.1.1 Check string voltage

To measure the open circuit voltage (VOC) and polarity of the individual strings, perform the following steps:



WARNING

When the fuse holders are closed, parallel strings on the same MPPT are connected together. If there is a voltage difference between the parallel strings such as different string lengths, current will flow between the parallel strings. Opening and closing the fuse holder in this instance is the same as opening and closing under load. Damage to equipment and /or injury to personnel may occur.

- 1). Ensure that all fuse holders are open.
- 2). Connect the positive lead of the meter to the positive string cable of the string under test. Connect the negative lead of the meter to the negative string cable of the string under test.

- 3). Measure the voltage present between the positive and negative wires of each string. If the open circuit voltage of the string is near the maximum value accepted by the inverter, verify the string length. Low ambient temperatures cause an increase in the string voltage causing potential damage to the inverter.
- 4). Check the polarity of the string. All digital meters have a negative ("-") indicator that indicates when a voltage is negative; in this case a string connected in reverse polarity.



WARNING

Input voltages higher than the maximum value accepted by the inverter (see "Specifications" in Section 9) may damage the inverter. Although Canadian Solar inverters feature reverse polarity protection, prolonged connection in reverse polarity may damage these protection circuits and/or the inverter.

5.4.3.2 Leakage to ground

Measure leakage to ground to check for a DC ground fault.

5.4.3.2.1 Detection of leakage to ground

Canadian Solar inverters are transformer-less and do not have an array connection to ground. Any measurement of a fixed voltage between ground and either the positive or negative string wiring indicates a leakage (ground fault) to ground and must be corrected prior to energizing the inverter or damage to the inverter may result.

To measure leakage to ground, perform the following steps:

- 1). Ensure that all fuse holders are open.
- 2). Ensure that neither negative nor positive DC conductors are connected to the ground strip.
- 3). Measure each string positive connection to ground.
- 4). Measure each string negative connection to ground.
- 5). Verify the voltage is "floating", not a consistent voltage to ground. Make sure you notice the units of the measurement. mV is not the same as V.
- 6). Do not close the fuse holder and connect the strings if a leakage to ground has been detected. Improper operation and damage to the inverter may result.

Once all DC tests have been completed, close the fuse holders.

5.4.4 AC configuration

Verify AC configuration.

5.4.4.1 Measure VAC and frequency

Measure VAC and verify voltage is within local grid standards.

- 1). Measure each phase to ground (L-G).
- 2). Measure phases to the other phases in pairs (L-L). PHA to PH B, PH B to PH C and PH C to PHA.
- 3). If the meter is equipped, measure the frequency of each phase to ground.
- 4). Ensure each measurement is within local grid standards and the inverter specifications as noted in Section 9 "Specifications".

5.4.4.2 Phase rotation test

A phase rotation test is recommended to ensure the phases have been connected in the appropriate order. Canadian Solar inverters do not require a specific phase rotation connection. However, the local utility may require a specific phase rotation or a record of the phase configuration of the installation.

6.1 Start-up procedure

To start-up the inverter, it is mandatory that the steps below are followed in the exact order outlined.

- 1). Ensure the commissioning checks in Section 5 have been performed.
- 2). Switch the AC switch ON.
- 3). Switch the DC switch ON. If the PV array (DC) voltage is higher than the inverter's start-up voltage, the inverter will turn on. The red DC POWER LED and LCD will be continuously lit.
- 4). Canadian Solar inverters are powered from the DC side. When the inverter detects DC power that is within start-up and operating ranges, the inverter will turn on. After turn-on, the inverter will check internal parameters, sense and monitor AC voltage, hertz rate and the stability of the supply grid. During this period, the green OPERATION LED will flash and the LCD screen will show INITIALIZING. This tells the operator that the inverter is preparing to generate AC power.
- 5). After the locally mandated delay (300 seconds for IEEE-1547 compliant inverters), the inverter will start generating AC power. The green OPERATION LED will light continuously and the LCD screen will show GENERATING.



CAUTION

The inverter's surface temperature can reach up to 75°C (167° F). To avoid risk of burns, do not touch the surface when the inverter is in the operational mode. Additionally, the inverter must be installed out of the reach of children.

6.2 Shutdown procedure

To stop the inverter, it is mandatory that the steps below are followed in the exact order outlined.

- 1). Switch AC switch OFF.
- 2). Wait approximately 30 seconds (during this time, the AC side capacitors are dissipating energy). If the inverter has DC voltage above the start-up threshold, the red POWER LED will be lit. Switch the DC switch OFF.
- 3). Confirm all LED's switch OFF (~one (1) minute).



CAUTION

Although the inverter DC disconnect switch is in the OFF position and all the LED's are OFF, operators must wait five (5) minutes after the DC power source has been disconnected before opening the inverter cabinet. DC side capacitors can take up to five (5) minutes to dissipate all stored energy.

In normal operation, LCD screen alternatively shows inverter power and operation status (see Figure 6.1). The screen can be scrolled manually by pressing the UP/DOWN keys. Pressing the ENTER key gives access to Main Menu.

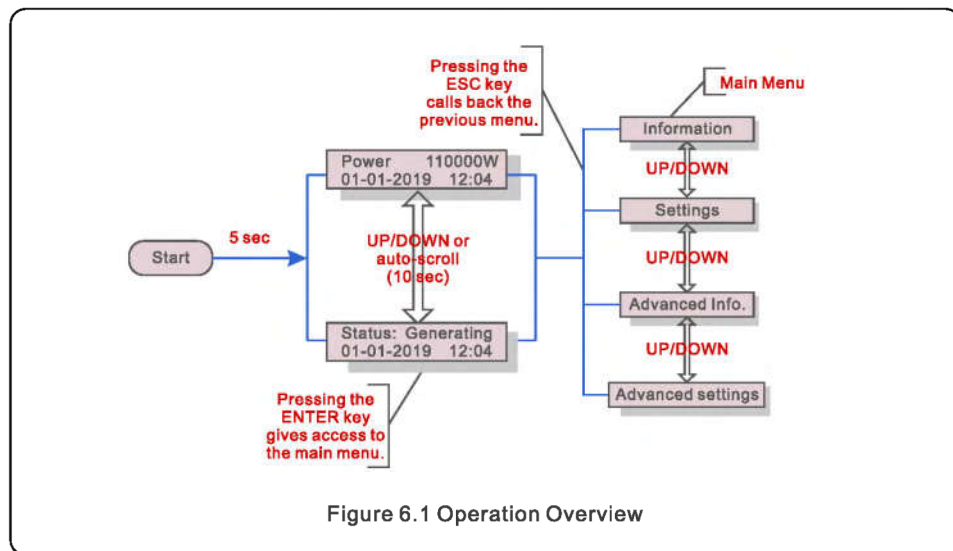

Figure 6.1 Operation Overview

6.3 Main Menu

There are four submenus in the Main Menu (see Figure 6.1):

1. Information
2. Settings
3. Advanced Info.
4. Advanced Settings

6.4 Information

The Canadian Solar three Phase Inverter main menu provides access to operational data and information. The information is displayed by selecting "Information" from the menu and then by scrolling up or down.

Display	Duration	Description
VPV_Total: 1000.0V IPV_Total: +99.0A	10 sec	VPV_Total: Shows input voltage total. IPV_Total: Shows input current total.
V_A: 345.7V I_A: 109.0A	10 sec	V_A: Shows the grid's voltage value. I_A: Shows the grid's current value.
V_C: 345.0V I_C: 109.8A	10 sec	V_C: Shows the grid's voltage value. I_C: Shows the grid's current value.
Status: Generating Power: 1488W	10 sec	Status: Shows instant status of the Inverter. Power: Shows instant output power value.
Rea_Power: 000Var App_Power: VA	10 sec	Rea_Power: Shows the reactive power of the inverter. App_Power: Shows the apparent power of the inverter.
Grid Frequency F_Grid 50.06Hz	10 sec	F_Grid: Shows the grid's frequency value.
Total Energy 0258458 kwh	10 sec	Total generated energy value.
This Month: 0123kwh Last Month: 0123kwh	10 sec	This Month: Total energy generated this month. Last Month: Total energy generated last month.
Today: 15.1kwh Yesterday: 13.5kwh	10 sec	Today: Total energy generated today. Yesterday: Total energy generated yesterday.
Inverter SN 0000000000000	10 sec	Display series number of the inverter.
Work Mode: Volt-watt DRM NO.:08	10 sec	Work Mode: Shows current working mode. DRM NO.: Shows DRM Number.
I_DC01: +05.0A I_DC02: +04.9A ... I_DC20: +05.2A	10 sec	I_DC01 : Shows input 01 current value. I_DC02 : Shows input 02 current value. ... I_DC20 : Shows input 20 current value.

Table 6.1 Information list

6.4.1 Lock Screen

Pressing the ESC key returns to the Main Menu. Pressing the ENTER key locks (Figure 6.2(a)) or unlocks (Figure 6.2 (b)) the screen.

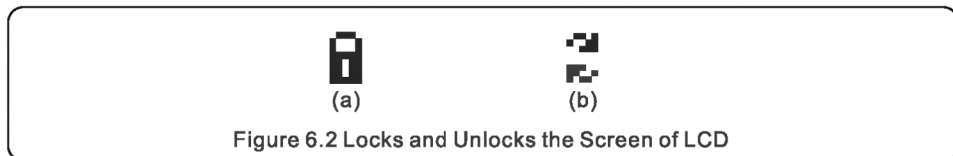

6.5 Settings

The following submenus are displayed when the Settings menu is selected:

- 1.Set Time
- 2.Set Address

6.5.1 Set Time

This function allows time and date setting. When this function is selected, the LCD will display a screen as shown in Figure 6.3.

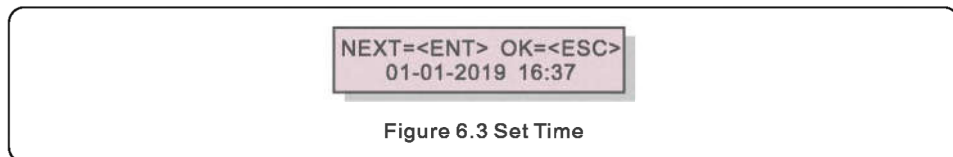

Press the UP/DOWN keys to set time and data. Press the ENTER key to move from one digit to the next (from left to right). Press the ESC key to save the settings and return to the previous menu.

6.5.2 Set Address

This function is used to set the address when muti inverters are connected to three monitor. The address number can be assigned from "01" to "99"(see Figure 6.4). The default address number of Canadian Solar Three Phase Inverter is "01".

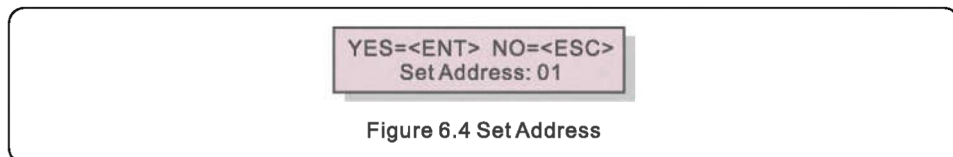

Press the UP/DOWN keys to set the address. Press the ENTER key to save the settings. Press the ESC key to cancel the change and return to the previous menu.

6.6 Advanced Info - Technicians Only



NOTE:

To access to this area is for fully qualified and accredited technicians only. Enter menu "Advanced Info." and "Advanced settings" (need password) .

Select "Advanced Info." from the Main Menu. The screen will require the password as below:

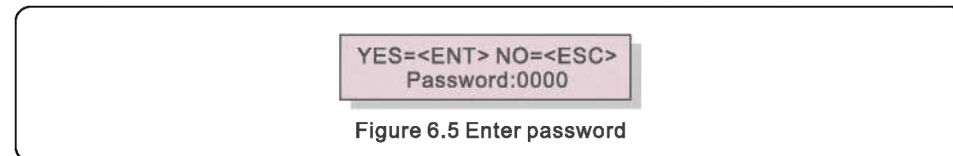

After enter the correct password the Main Menu will display a screen and be able to access to the following information.

- 1.Alarm Message
2. Running message
- 3.Version
4. Daily Energy
5. Monthly Energy
6. Yearly Energy
7. Daily Records
- 8.Communication Data
9. Warning Message

The screen can be scrolled manually by pressing the UP/DOWN keys. Pressing the ENTER key gives access to a submenu. Press the ESC key to return to the Main Menu.

6.6.1 Alarm Message

The display shows the 100 latest alarm messages (see Figure 6.6). Screens can be scrolled manually by pressing the UP/ DOWN keys. Press the ESC key to return to the previous menu.

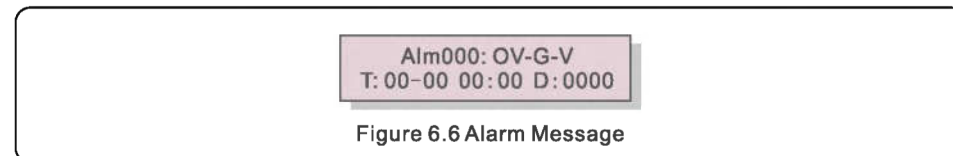

6.6.2 Running Message

This function is for maintainece person to get running message such as internal temperature, Standard No.1,2,etc.

Screens can be scrolled manually by pressing the UP/DOWN keys.

6.6.3 Version

The screen shows the model version of the inverter. And the screen will show the software ver by pressing the UP and DOWN at the same time.(see Figure 6.7).

Model: 08
Software Version: D20001

Figure 6.7 Model Version and Software Version

6.6.4 Daily Energy

The function is for checking the energy generation for selected day.

YES=<ENT> NO=<ESC>
Select: 2019-01-01

Figure 6.8 Select date for daily energy

Press DOWN key to move the cursor to day, month and year, press UP key to change the digit. Press Enter after the date is fixed.

2019-01-01: 051.3kWh
2019-01-01: 061.5kWh

Figure 6.9 Daily energy

Press UP/DOWN key to move one date from another.

6.6.5 Monthly Energy

The function is for checking the energy generation for selected month.

YES=<ENT> NO=<ESC>
Select: 2019-01

Figure 6.10 Select month for monthly energy

Press DOWN key to move the cursor to day and month, press UP key to change the digit. Press Enter after the date is fixed.

2019-01: 0510kWh
2019-01: 0610kWh

Figure 6.11 Month energy

Press UP/DOWN key to move one date from another.

6.6.6 Yearly Energy

The function is for checking the energy generation for selected year.

YES=<ENT> NO=<ESC>
Select: 2019

Figure 6.12 Select year for yearly energy

Press DOWN key to move the cursor to day and year, press UP key to change the digit. Press Enter after the date is fixed.

2018: 0017513kWh
2017: 0165879kWh

Figure 6.13 Yearly energy

Press UP/DOWN key to move one date from another.

6.6.7 Daily Records

The screen shows history of changing settings. Only for maintenance personnel.

6.6.8 Communication Data

The screen shows the internal data of the Inverter (see Figure 6.14), which is for service technicians only.

01-05: 01 25 E4 9D AA
06-10: C2 B5 E4 9D 55

Figure 6.14 Communication Data

6.6.9 Warning Message

The display shows the 100 latest warn messages (see Figure 6.15). Screens can be scrolled manually by pressing the UP/ DOWN keys. Press the ESC key to return to the previous menu.

Msg000:
T: 00-00 00:00 D:0000

Figure 6.15 Warning Message

6.7 Advanced Settings - Technicians Only



NOTE:

To access to this area is for fully qualified and accredited technicians only. Please follow 6.4 to enter password to access this menu.

Select Advanced Settings from the Main Menu to access the following options:

1. Select Standard
2. Grid ON/OFF
3. Clear Energy
4. Reset Password
5. Power Control
6. Calibrate Energy
7. Special Settings
8. STD. Mode Settings
9. Restore Settings
10. HMI Update
11. External EPM set
12. Restart HMI
13. Debug Parameter
14. DSP Update
15. Compensation Set
16. I/V Curve

6.7.1 Selecting Standard

This function is used to select the grid's reference standard (see Figure 6.16).

YES=<ENT> NO=<ESC>
Standard:G99

Figure 6.16

Selecting the "User-Def" menu will access to the following submenu (see Figure 6.17),

→ OV-G-V1: 400V
OV-G-V1-T: 1.0S

Figure 6.17

Below is the setting range for "User-Def". Using this function, the limits can be changed manually. (These voltage values are the phase voltage)

OV-G-V1: 300---480V	OV-G-F1: 50.2-63Hz
OV-G-V1-T: 0.01---9S	OV-G-F1-T: 0.01---9S
OV-G-V2: 300---490V	OV-G-F2: 51-63Hz
OV-G-V2-T: 0.01---1S	OV-G-F2-T: 0.01---9S
UN-G-V1: 173---336V	UN-G-F1: 47-59.5Hz
UN-G-V1-T: 0.01---9S	UN-G-F1-T: 0.01---9S
UN-G-V2: 132---319V	UN-G-F2: 47-59Hz
UN-G-V2-T: 0.01---1S	UN-G-F2-T: 0.01---9S
Startup-T: 10-600S	Restore-T: 10-600S

Table 6.2 Setting ranges for User-Def (L-N)



NOTE

The initial value of the User-Def standard is for reference only. It does not represent a correct value suitable for use.

6.7.2 Grid ON/OFF

This function is used to start up or stop the power generation of Canadian Solar Three Phase Inverter (see Figure 6.18).

→ Grid ON
Grid OFF

Figure 6.18 Set Grid ON/OFF

Screens can be scrolled manually by pressing the UP/DOWN keys. Press the ENTER key to save the setting. Press the ESC key to return to the previous menu.

6.7.3 Clear Energy

Clear Energy can reset the history yield of inverter



These two functions are applicable by maintenance personnel only, wrong operation will prevent the inverter from working properly.

6.7.4 Reset Password

This function is used to set the new password for menu "Advanced info." and "Advanced information" (see Figure 6.19).

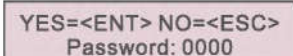

Figure 6.19 Set new password

Enter the right password before set new password. Press the DOWN key to move the cursor, Press the UP key to revise the value. Press the ENTER key to execute the setting. Press the ESC key to return to the previous menu.

6.7.5 Power Control

Active and reactive power can be set through power setting button. There are 5 item for this sub menu:

1. Set output power
2. Set Reactive Power
3. Out_P With Restore
4. Rea_P With Restore
5. Select PF Curve



This function is applicable by maintenance personnel only, wrong operation will prevent the inverter from reaching maximum power.

6.7.6 Calibrate Energy

Maintenance or replacement could clear or cause a different value of total energy. Use this function could allow user to revise the value of total energy to the same value as before. If the monitoring website is used the data will be synchronous with this setting automatically. (see Figure 6.20).



Figure 6.20 Calibrate energy

Press the DOWN key to move the cursor, Press the UP key to revise the value. Press the ENTER key to execute the setting. Press the ESC key to return to the previous menu.

6.7.7 Special Settings



This function is applicable by maintenance personnel only, wrong operation will prevent the inverter from reaching maximum power.

6.7.8 STD Mode Settings

Selecting "STD Mode. Settings" displays the sub-menu shown below:

1. Working Mode Set
2. Power Rate Limit
3. Freq Derate Set
4. 10mins Voltage Set
5. Power Priority
6. Initial Settings
7. Voltage PCC Set



This function is applicable by maintenance personnel only, wrong operation will prevent the inverter from reaching maximum power.

6.7.9 Restore Settings

There are 5 items in initial setting submenu.

Restore setting could set all item in 6.5.7 special setting to default.

The screen shows as below:

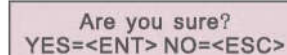

Figure 6.41 Restore Settings

Press the Enter key to save the setting after setting grid off. Press the ESC key to return the previous mean.

6.7.10 HMI Update



This section is applicable to maintenance personnel only.

Selecting "Updater" displays the sub-menu shown below:

```
HMI Current Ver.: 02
YES=<ENT> NO=<ESC>
```

Figure 6.42

Updater is for updating LCD firmware. Press the ENTER key to start the process. Press the ESC key to return to the previous menu.

6.7.11 External EPM Set

This function is turned on when the EPM is external.

```
YES=<ENT> NO=<ESC>
Fail Safe Set:ON
```

Figure 6.43 Set the Fail Safe ON/OFF

6.7.12 Restart HMI

The function is used for restart the HMI.



This function is applicable by maintenance personnel only, wrong operation will prevent the inverter from reaching maximum power.

6.7.13 Debug Parameter



This section is applicable to maintenance personnel only.

Debug Parameter as shown as below:

```
→ S16DAT1: +0000
S16DAT2: +0000
S16DAT3: +0000
S16DAT4: +0000
S16DAT5: +0000
S16DAT6: +0000
S16DAT7: +0000
S16DAT8: +0000
```

Figure 6.44

Press the UP/DOWN keys to scroll through items. Press the ENTER key to select. Press the DOWN key to scroll and press the UP key to change the value. Press the ENTER key to save the setting. Press the ESC key to cancel changes and return to the previous menu.

6.7.14 FAN Test



This section is applicable to maintenance personnel only.

Selecting "Fan Test" displays the sub-menu shown below:

```
Are you sure?
YES=<ENT> NO=<ESC>
```

Figure 6.45

Fan Test is a factory test function. Press the ENTER key to start the test. Press the ESC key to return to the previous menu.

6.7.15 DSP Update

The function is used for update the DSP.



This function is applicable by maintenance personnel only, wrong operation will prevent the inverter from reaching maximum power.

6.7.16 Compensation Set

This function is used to calibrate inverter output energy and voltage. It will not impact the energy count for inverter with RGM.

Two sections are included: Power Parameter and Voltage Parameter.

The screen shows:

YES=<ENT> NO=<ESC>
Power para: 1.000

Figure 6.46 Power Rate Limit

Press the Down key to move the cursor.

Press the Up key to change the digit.

Please press the Enter to save the setting and press the ESC key to return to the previous menu.



This setting is used for grid operators, do not change this setting unless specifically instructed to.

6.7.17 I/V Curve

This function is used to scan the I/V characteristic curves of each PV strings.

→ Set I/V Curve
I/V Curve Scan

Figure 6.47 I/V Curve

6.7.17.1 Set I/V Curve

This setting can set the scanning voltage start point and the voltage interval.

Start_V: 850V
Interval_V: 010V

Figure 6.48 Set I/V Curve

Start_V: The start voltage of the I/V scan. (Adjustable from 850V-1000V)

Interval_V: The scanning voltage interval. (Adjustable from 001V-100V)

In total, 60 data points can be scanned.

The max scanning range is from 850-1450V.

6.7.17.2 I/V Curve Scan

Press "ENT" to start the I/V curve scan.

Scanning...01

Figure 6.49 I/V Curve Scan (1)

After it is completed, the screen will display "Scan OK" and then enter the following section.

Select String No.: 01

Figure 6.50 I/V Curve Scan (2)

01_850V: 9.56A
02_860V: 9.44A

Figure 6.51 I/V Curve Scan (3)

Canadian Solar Three Phase Inverter does not require any regular maintenance. However, cleaning the dust on heat-sink will help the inverter to dissipate the heat and increase its life time. The dust can be removed with a soft brush.



CAUTION:

Do not touch the inverter's surface when it is operating. Some parts of the inverter may be hot and cause burns. Turn off the inverter (refer to Section 6.2) and wait for a cool-down period before any maintenance or cleaning operation.

The LCD and the LED status indicator lights can be cleaned with a damp cloth if they are too dirty to be read.



NOTE:

Never use any solvents, abrasives or corrosive materials to clean the inverter.

7.1 Anti-PID Function

CSI-100KTL-GI-E, CSI-125KTL-GI-E integrates optional Anti-PID module and it can recover the PID effect during night thus protect the PV system from degradation.

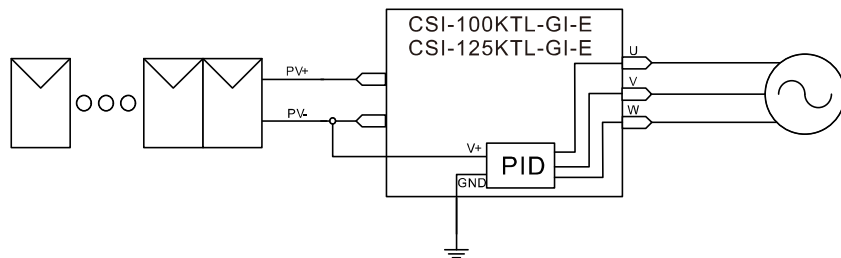

Figure 7.1

The Anti-PID module repairs the PID effect of the PV model at night. When operating, the inverter LCD screen displays "PID-repairing" information, and the red light is on. The Anti-PID function is always ON when AC is applied. If maintenance is required and turn off the AC switch can disable the Anti-PID function.



WARNING :

The PID function is automatic. When the DC bus voltage is lower than 260Vdc, the PID module will start creating 650 Vdc between PV- and ground. No need any control or settings



NOTE:

If you need to maintain the inverter at night, please turn off the AC switch first, then turn off the DC switch, and wait 5 minutes before you do other operations.

7.2 Fan Maintenance

If the fan does not work properly, the inverter will not be cooled effectively, and it may affect the effective operation of the inverter .

Therefore, it is necessary to clean or replace a broken fan as follows:

1. Turn off the "Grid ON/OFF" switch on the inverter LCD.
2. Disconnect the AC power.
3. Turn the DC switch to "OFF" position.
4. Wait for 15 minutes at least.

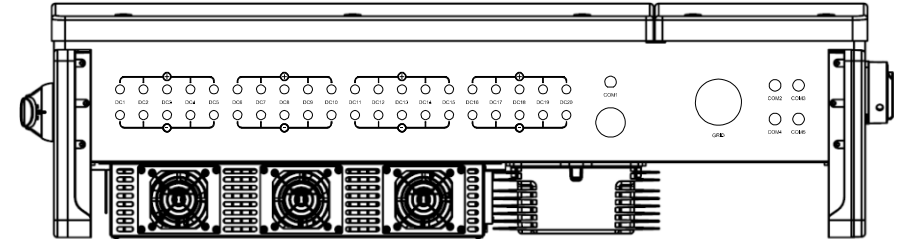

Figure 7.2

5. Remove the 4 screws on the fan plate and pull out the fan assembly slowly.

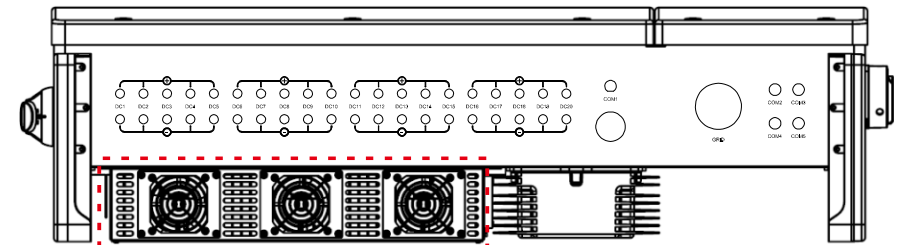

Figure 7.3

6. Disconnect the fan connector carefully and take out the fan.

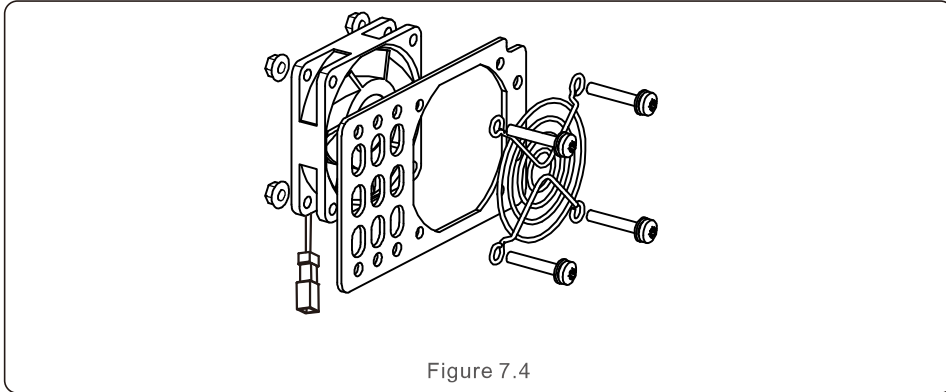

Figure 7.4

7. Clean or replace the fan. Assemble the fan on the rack.

8. Connect the electrical wire and reinstall the fan assembly. Restart the inverter.

7.3 Fuse Maintenance

If the fuse is blown, it is necessary to replace the blown fuse.

1. Turn the AC switch to "OFF" position.
2. Turn the DC switch to "OFF" position.
3. Wait 15 minutes for inverter capacitors to de-energize.
4. Remove the 6 screws on the inverter cover and remove the cover.
5. Open fuse holder, remove and replace blown fuse, close fuse holder.
6. Replace cover, torque screws to 2.4-2.6NM.
7. Restart inverter using normal start-up procedure.

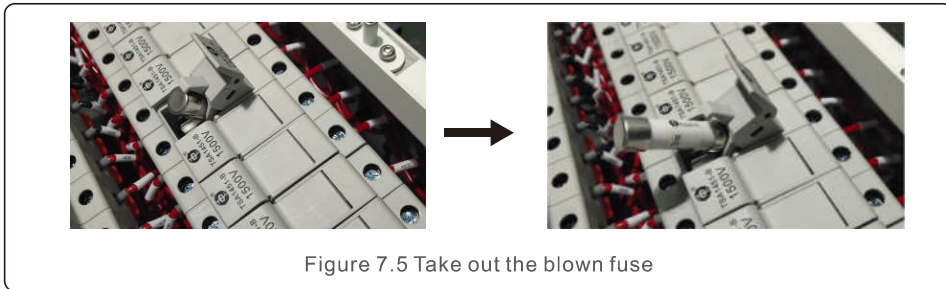

Figure 7.5 Take out the blown fuse

8. Use a multimeter to check if the fuse is intact before placing a new fuse.

If it is intact, put it in the fuse holder and close the fuse cover.



The fuse spec is 1500V/20A.
When replacing the fuses, please select the fuses with the same specification.

7.4 Surge Protection Device Maintenance

If surge protection device is damaged, it will affect the safety of the inverter. It is necessary to replace it with a new lightning protection module.

1. Disconnect the AC power.
2. Turn the DC switch to "OFF" position.
3. Wait for 15 minutes at least.
4. If DC surge protection device is damaged, remove the 6 screws on the inverter cover and open the cover. If AC surge protection device is damaged, remove the 4 screws on the wiring box cover and open the wiring box cover.
5. Press and hold the spring clip on the upper and lower sides of the damaged surge protection module and remove it. (See Figure 7.6)
Insert the new lightning protection module in the correct position.

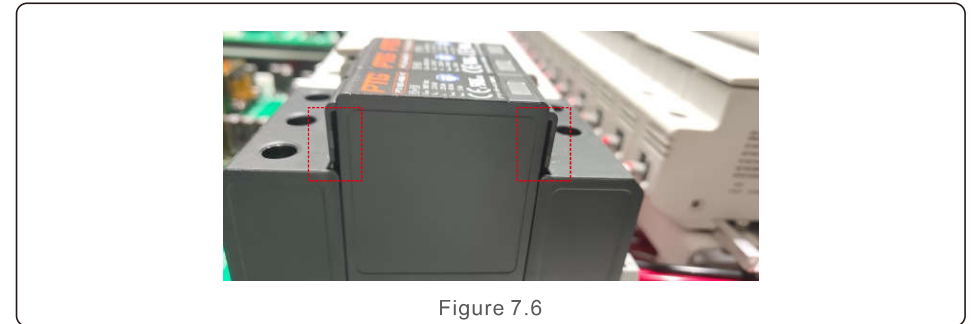

Figure 7.6



If the SPD fails or in malfunction. The inverter LCD will show "SPD-FAIL", please replace the SPD module accordingly

The inverter is designed in accordance with the most important international grid-tied standards and safety and electromagnetic compatibility requirements. Before delivering to the customer, the inverter has been subjected to several tests to ensure its optimal operation and reliability.

In case of failure, the LCD screen will display an alarm message. In this case, the inverter may stop feeding into the grid. The failure descriptions and their corresponding alarm messages are listed in Table 9.1:

Alarm Message	Failure description	Solution
No power	Inverter no power on LCD	1. Check PV input connections 2. Check DC input voltage (single phase >120V, three phase >350V) 3. Check if PV+/- is reversed
LCD show initializing all the time	Can not start-up	1. Check if the connector on main board or power board are fixed. 2. Check if the DSP connector to power board are fixed.
OV-G-V01/02/03/04	Over grid voltage	1. Resistant of AC cable is too high. Change bigger size grid cable 2. Adjust the protection limit if it's allowed by electrical company.
UN-G-V01/02	Under grid voltage	1. Use user define function to adjust the protection limit if it's allowed by electrical company.
OV-G-F01/02	Over grid frequency	
UN-G-F01/02	Under grid frequency	
G-IMP	High grid impedance	
NO-GRID	No grid voltage	1. Check connections and grid switch. 2. Check the grid voltage inside inverter terminal.
OV-DC01/02/03/04	Over DC voltage	1. Reduce the module number in series
OV-BUS	Over DC bus voltage	1. Check inverter inductor connection 2. Check driver connection
UN-BUS01/02	Under DC bus voltage	
GRID-INTF01/02	Grid interference	1. Restart inverter 2. Change power board
OV-G-I	Over grid current	
IGBT-OV-I	Over IGBT current	
DC-INTF OV-DCA-I	DC input overcurrent	1. Restart inverter 2. Identify and remove the string to the fault MPPT 2. Change power board
IGFOL-F	Grid current tracking fail	1. Restart inverter or contact installer.
IG-AD	Grid current sampling fail	
OV-TEM	Over Temperature	1. Check inverter surrounding ventilation. 2. Check if there's sunshine direct on inverter in hot weather.

Alarm Message	Failure description	Solution
INI-FAULT	Initialization system fault	1. Restart inverter or contact installer.
DSP-B-FAULT	Comm. failure between main and slave DSP	
12Power-FAULT	12V power supply fault	
PV ISO-PRO 01/02	PV isolation protection	1. Remove all DC input, reconnect and restart inverter one by one. 2. Identify which string cause the fault and check the isolation of the string.
lLeak-PRO 01/02/03/04	Leakage current protection	1. Check AC and DC connection 2. Check inverter inside cable connection.
RelayChk-FAIL	Relay check fail	1. Restart inverter or contact installer.
DCinj-FAULT	High DC Injection current	
AFCI self-detection (model with AFCI module)	AFCI module self-detect fault	1. Restart inverter or connect technician.
Arcing protection (model with AFCI module)	Detect arc in DC circuit	1. Check inverter connection whether arc exists and restart inverter.

Table 8.1 Fault message and description



NOTE:

If the inverter displays any alarm message as listed in Table 8.1; please turn off the inverter (refer to Section 5.2 to stop your inverter) and wait for 15 minutes before restarting it (refer to Section 5.1 to start your inverter). If the failure persists, please contact your local distributor or the service center. Please keep ready with you the following information before contacting us.

1. Serial number of Canadian Solar Three Phase Inverter;
2. The distributor/dealer of Canadian Solar Three Phase Inverter (if available);
3. Installation date.
4. The description of problem (i.e. the alarm message displayed on the LCD and the status of the LED status indicator lights. Other readings obtained from the Information submenu (refer to Section 6.2) will also be helpful.);
5. The PV array configuration (e.g. number of panels, capacity of panels, number of strings, etc.);
6. Your contact details.

9. Specifications



Model	CSI-100KTL-GI-E
Max. DC input power (Watts)	150000
Max. DC input voltage (Volts)	1500
Rated DC voltage (Volts)	950
Start-up voltage (Volts)	900
MPPT voltage range (Volts)	860...1450
Max. input current (Amps)	120
Max short circuit input current (Amps)	250
MPPT number/Max input strings number	1/16
Rated output power (Watts)	100000
Max. output power (Watts)	100000
Max. apparent output power (VA)	100000
Rated grid voltage (Volts)	3/PE~600
Rated output current (Amps)	96
Power Factor (at rated output power)	0.8leading~0.8lagging
THDi (at rated output power)	<3%
Rated grid frequency (Hertz)	50/60
Max. efficiency	99.1%
EU efficiency	98.6%
MPPT efficiency	99.9%
Dimensions (W*H*D)	1176*713.5*315 (mm) / 46.3*28.1*12.4 (inch)
Weight	84kg / 185.2lb
Topology	Transformerless
Self consumption (night)	< 3W (without anti-PID)
Operating ambient temperature range	-25°C . . . +60°C
Relative humidity	0~100%
Ingress protection	NEMA4X/IP65
Noise emission	≤55dB(A)
Cooling concept	Fan cooling
Max. operation altitude	4000m
Compliance	IEC62109-1/-2, IEC61000-6-2/-4, IEC 61727, IEC 62116, VDE4105, VDE0126-1-1, EN50530
DC connection	MC4
AC connection	OT Terminal connectors (Max. 185mm ²)
Display	LCD
Communication connections	RS485/Ethernet
OTA update	Yes
Warranty	5 years standard (extend to 20 years)



9. Specifications

Model	CSI-125KTL-GI-E
Max. DC input power (Watts)	187000
Max. DC input voltage (Volts)	1500
Rated DC voltage (Volts)	950
Start-up voltage (Volts)	900
MPPT voltage range (Volts)	860...1450
Max. input current (Amps)	150
Max short circuit input current (Amps)	300
MPPT number/Max input strings number	1/20
Rated output power (Watts)	125000
Max. output power (Watts)	125000
Max. apparent output power (VA)	125000
Rated grid voltage (Volts)	3/PE~600
Rated output current (Amps)	120
Power Factor (at rated output power)	0.8leading~0.8lagging
THDi (at rated output power)	<3%
Rated grid frequency (Hertz)	50/60
Max. efficiency	99.1%
EU efficiency	98.6%
MPPT efficiency	99.9%
Dimensions (W*H*D)	1176*713.5*315 (mm) / 46.3*28.1*12.4 (inch)
Weight	84kg / 185.2lb
Topology	Transformerless
Self consumption (night)	< 3W (without anti-PID)
Operating ambient temperature range	-25°C . . . +60°C
Relative humidity	0~100%
Ingress protection	NEMA4X/IP65
Noise emission	≤55dB(A)
Cooling concept	Fan cooling
Max. operation altitude	4000m
Compliance	IEC62109-1/-2, IEC61000-6-2/-4, IEC 61727, IEC 62116, VDE4105, VDE0126-1-1, EN50530
DC connection	MC4
AC connection	OT Terminal connectors (Max. 185mm ²)
Display	LCD
Communication connections	RS485/Ethernet
OTA update	Yes
Warranty	5 years standard (extend to 20 years)

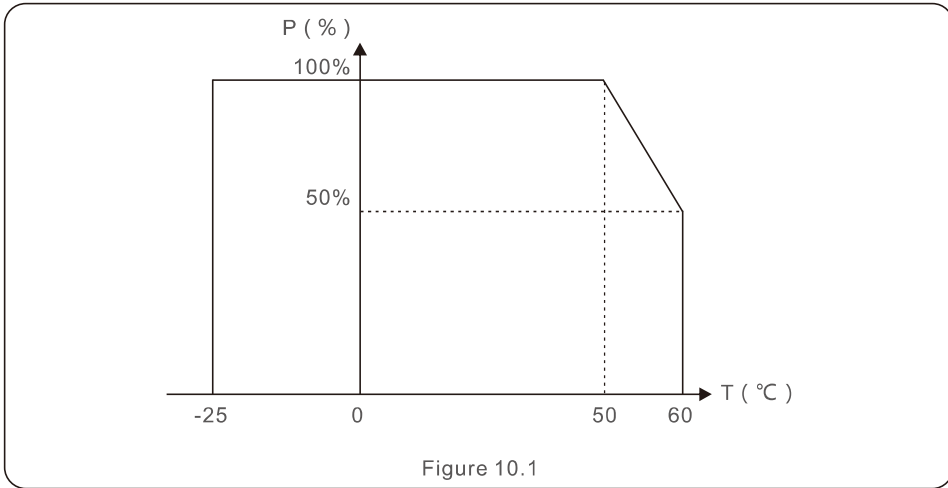

Figure 10.1

Comments:

A thermal sensor inside the inverter is calibrated to determine ambient temperature. All inverters will begin a sloped derate at 50C ending at 50% output power at 60C.

Temperatures above 60C and below -25C will derate to 0% output power.

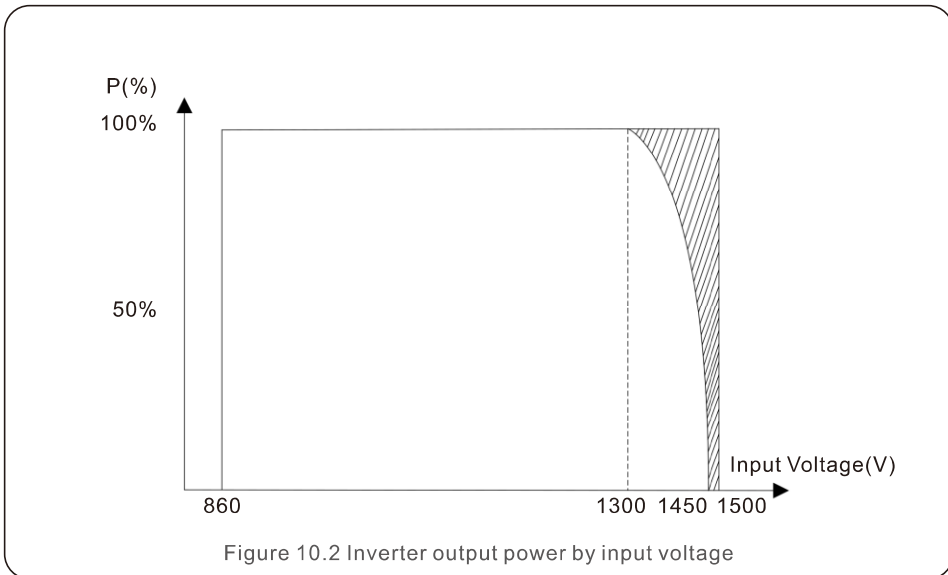

Figure 10.2 Inverter output power by input voltage

PROJECT NAME _____

LOCATION _____ NUMBER _____



INSTALLATION AND COMMISSIONING CHECKLIST

3 PHASE STRING INVERTERS (KTL SERIES)

Warning: This checklist is not a replacement for the user manual. Please read the user manual prior to inverter site selection and installation.

Step	No.	Content	Details	Values / Notes	Conclusion
INSTALLATION	1	Installation environment	Ensure installation site meets environmental and physical constraints.		<input type="checkbox"/> Good <input type="checkbox"/> Poor
	2	Unpacking	Check inverter condition after unpacking.		<input type="checkbox"/> Good <input type="checkbox"/> Poor
	3	Mounting bracket installation	Install inverter mounting bracket according to installation instructions in user manual. For allowable tilt angle refer to the installation manual.		<input type="checkbox"/> Completed Record Tilt Angle in Notes
	4	Inverter installation	Carefully install the inverter to the mounting bracket and ensure it is firmly attached. Ensure the inverter has proper clearances and are properly ventilated.		<input type="checkbox"/> Completed
	5	Serial number	Record the product serial numbers located on the side label.		Serial Numbers; attached list
	6	Solar modules	Confirm PV module installation completion. Record the total power of the PV modules.		<input type="checkbox"/> Completed Record kWp in Notes
	7	DC input and AC output connection	Switch off the DC and AC distribution unit, connect DC to PV terminals of inverter, and connect AC to AC terminals of inverter. Ensure proper polarity and cable size. Torque to specifications.		<input type="checkbox"/> Completed Record Torque in Notes
	8	PV voltage	Measure and record DC voltage. Ensure voltage and polarities are correct. Confirm the voltages are within 5% tolerance to what was tested.		<input type="checkbox"/> Completed Record V_{DC} in Notes
	9	AC grid	Measure and record AC voltage and frequency. Confirm the V_{AC} voltages are within 5% tolerance to what was tested.		<input type="checkbox"/> Completed Record V_{AC} in Notes
	10	Grounding cable	Ensure ground cable is firmly attached to grounding lug.		<input type="checkbox"/> Good <input type="checkbox"/> Poor

PROJECT NAME _____

LOCATION _____ NUMBER _____



INSTALLATION AND COMMISSIONING CHECKLIST

3 PHASE STRING INVERTERS (KTL SERIES)

Warning: This checklist is not a replacement for the user manual. Please read the user manual prior to inverter site selection and installation.

Step	No.	Content	Details	Values / Notes	Conclusion
COMMISSIONING	1	Communication cable (if function is used)	Connect the RS485 cable to the communication port.		[] Completed
	2	Supply DC / AC power	<p>CSI-xx-KTL-GI:</p> <ol style="list-style-type: none"> 1. Switch the grid supply main Switch (AC) ON first. 2. Switch the DC switch ON. If the voltages of PV arrays are higher than start up voltage, the inverter will turn on. The red LED power will be continuously lit. 3. When both the DC and the AC sides supply to the inverter, it will be ready to generate power. Initially, the inverter will check both its internal parameters and the parameters of the AC grid, to ensure that they are within the acceptable limits. At the same time, the green LED will lash and the LCD displays the information of INITIALIZING. 		[] Completed Record LEDs status in Notes

PROJECT NAME _____

LOCATION _____ NUMBER _____



INSTALLATION AND COMMISSIONING CHECKLIST

3 PHASE STRING INVERTERS (KTL SERIES)

Warning: This checklist is not a replacement for the user manual. Please read the user manual prior to inverter site selection and installation.

Step	No.	Content	Details	Values / Notes	Conclusion
COMMISSIONING	3	Waiting time	CSI-xx-KTL-GI: After 60-300 seconds (depending on local requirement), the inverter will start to generate power. The green LED will be on continuously and the LCD displays the information of GENERATING.		<input type="checkbox"/> Completed Record LEDs status in Notes
	4	Power generation	After grid connection, record power output of inverter.		<input type="checkbox"/> Completed Record power in Notes
	5	Date & Time setting	Set the current date and time using the front panel interface.		<input type="checkbox"/> Completed Record current date/time in Notes
	6	Communication setting (if avail.)	Set communication with a unique address for each inverter.		<input type="checkbox"/> Completed Record address in Notes
	7	Machine version	For maintenance and reference, please record the firmware revisions if applicable.		<input type="checkbox"/> Completed Record with serial numbers
	8	Operating parameter	Record operating parameters of the inverter. Verify IEC62109 or the corresponding On-grid setting is selected. De-rate inverter and attach de-rate sticker as required.		<input type="checkbox"/> Completed Record operating parameters in Notes
	9	Testing	Open and close the DC breaker to confirm whether the inverter reboots and shuts down automatically.		<input type="checkbox"/> Reboot successful <input type="checkbox"/> Not rebooting
	10	Completion	Installation and commissioning is complete if no abnormality.		<input type="checkbox"/> Good <input type="checkbox"/> Issues detected

PROJECT NAME _____

LOCATION _____ NUMBER _____



INSTALLATION AND COMMISSIONING CHECKLIST

3 PHASE STRING INVERTERS (KTL SERIES)

Warning: This checklist is not a replacement for the user manual. Please read the user manual prior to inverter site selection and installation.

System Owner: _____

Address / Location: _____

Inverter model: _____

Number of inverters: _____ Inverter mounting tilt: _____

Output power*: _____ Input DC voltage: _____

Grid: V Max: _____ V Min: _____ Frequency Max: _____ Min: _____

Configuration: MPPT Individual _____ MPPT Parallel _____

Monitoring: RS485: _____ Ethernet: _____

PV module manufacturer: _____ PV model: _____

DC cable size: _____ AC cable size: _____

Number of series connected modules in PV strings: _____

Number of PV strings in parallel per MPPT: _____

Total System size (DC Watts): _____

Note site typical arrangements and variances

Inverter firmware revision: DSP: _____ LCD: _____

Insulation limit (K): _____ PV start-up voltage: _____

Reactive compensation: _____ +/- PF

Monitoring equipment and supplier: _____

Transformer ratings, supplier: _____

*Specify de-rated power and add nameplate power in parenthesis

GENERAL COMMENTS / OBSERVATIONS:

PROJECT NAME _____

LOCATION _____ NUMBER _____



INSTALLATION AND COMMISSIONING CHECKLIST

3 PHASE STRING INVERTERS (KTL SERIES)

Warning: This checklist is not a replacement for the user manual. Please read the user manual prior to inverter site selection and installation.

Inverter serial numbers:

1

2

3

4

5

6

7

8

9

10

11

12

13

14

15

16

17

18

19

20

21

22

23

24

25

26

27

28

29

30

31

32

33

34

35

36

37

38

39

40

41

42

INSTALLER'S NAME _____

INSTALLER'S SIGNATURE _____

COMPANY _____

DATE _____