

**CSI-40K-T4001A-E**

**CSI-50K-T4001A-E**

**CSI-60K-T4001A-E**



## **PV Inverter Quick Installation Guide**

(Part No: 91000208; Release Date: May, 2023)

## 1 About This Guide

- 1) This guide only applies to the following inverters: CSI-40K-T4001A-E, CSI-50K-T4001A-E, CSI-60K-T4001A-E.
- 2) This instruction only provides an overview of the installation of the above inverters
- 3) Due to product version upgrade or other reasons, this guidance will be updated irregularly. Under no circumstances can this guide replace the user manual and the safety instructions on the product.
- 4) Please read the user manual and related standard specifications carefully before performing any operation on this series of products. You can scan the QR code on the left side of the device or at the end of this guide to obtain an electronic copy of the manual.
- 5) All operations on this series of products must be completed by professional technicians. Professional and technical personnel must be specially trained, read user manual, master the safety matters related to operation, and be familiar with local standards and electrical system safety specification.
- 6) Before installing the products, please check whether the products are complete, consistent with the order, and whether there is obvious damage. If there is any abnormality, please contact the local dealer or CSI Solar Co., Ltd.

## 2 Product Introduction

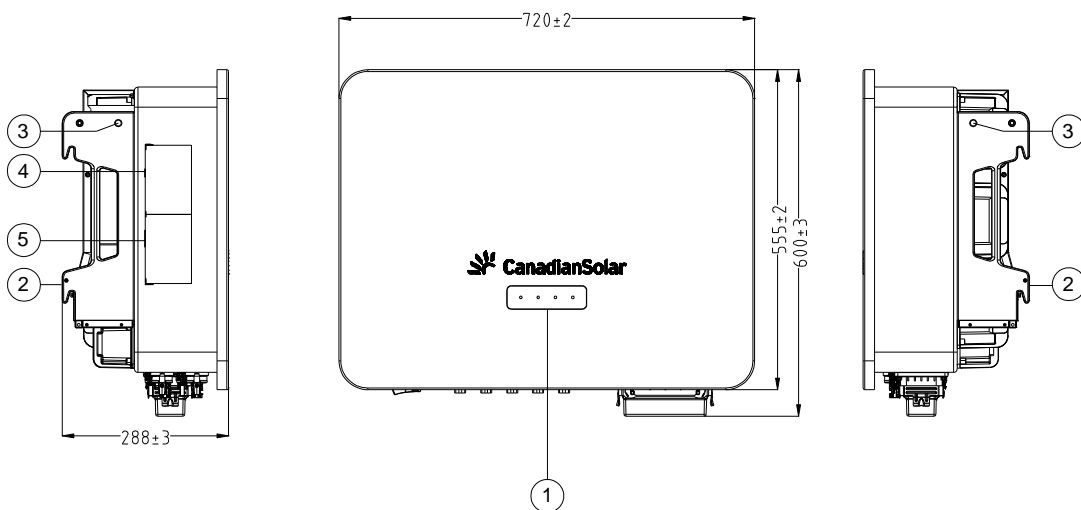

CSI-40K-T4001A-E

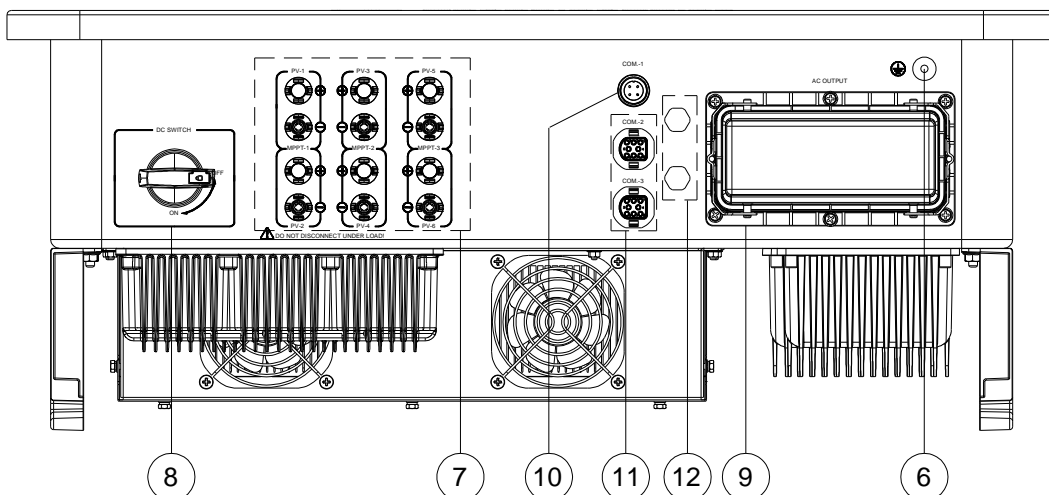

CSI-50K-T4001A-E

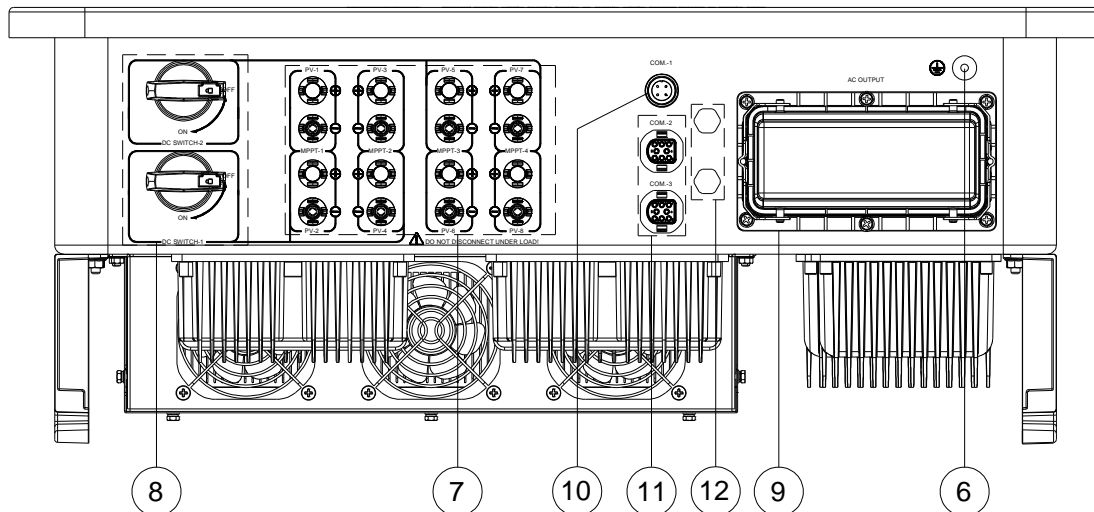

CSI-60K-T4001A-E

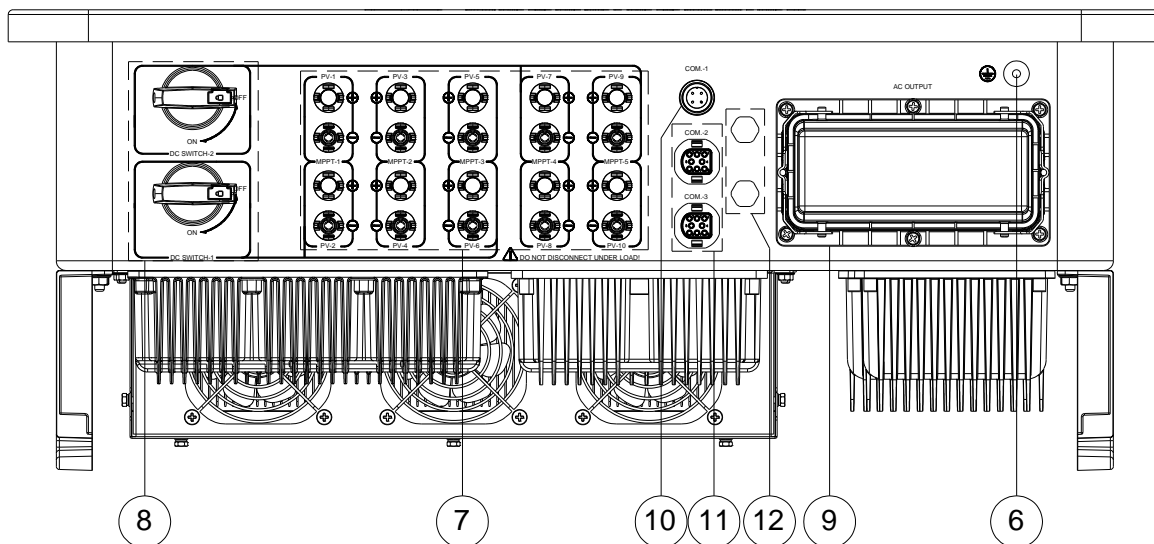

FIG 2-1 Product introduction (The picture is for reference only)

- |                                   |  |
|-----------------------------------|--|
| 1. LED indicator panel            | 7. PV input connectors                     |
| 2. Side handles and mounting ears | 8. DC disconnect switch                    |
| 3. M12 holes for lifting eyes     | 9. Cable gland for AC output               |
| 4. Rating label                   | 10. Cable gland for wireless communication |
| 5. Warning label                  | 11. Cable gland for communication          |
| 6. Additional grounding point     | 12. Breather valve                         |

### 3 Installation Environment Requirements

- 1) Do not install the inverter on the structures constructed of flammable, thermolabile or explosive materials.
- 2) Ensure the inverter is out of children's reach.
- 3) The ambient temperature should be between  $-30^{\circ}\text{C}$ ~  $60^{\circ}\text{C}$ .
- 4) The humidity of the installation location should be below 100% without condensation.
- 5) Do not install the inverter outdoors in salt, sulfur or other corrosive areas.
- 6) Prevent the inverter from direct exposure to sun, rain and snow.
- 7) The inverter should be well ventilated. Ensure air circulation.
- 8) Never install the inverter in living areas. The inverter will generate noise during operation, affecting daily life.
- 9) Install at an appropriate height for ease of viewing LED indicators and operating switches.

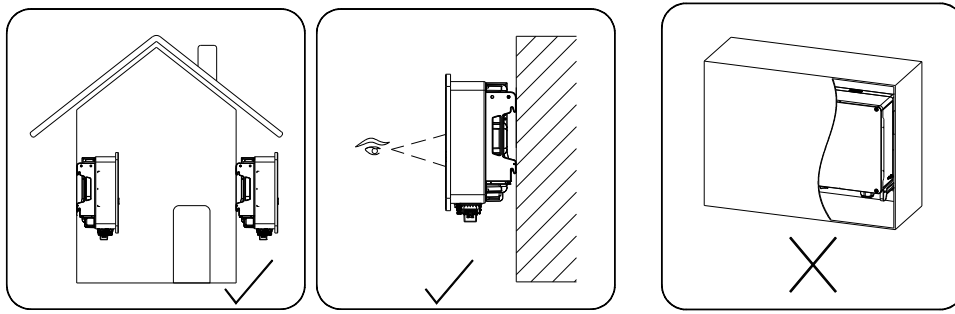

FIG 3-1 Installation site

### 3.1 Carrier Requirements

Min. load bearing capacity  $\geq 4$  times of inverter weight.

### 3.2 Installation Angle Requirements

It is recommended to install the inverter vertically. Forward installation or upside down installation is prohibited.

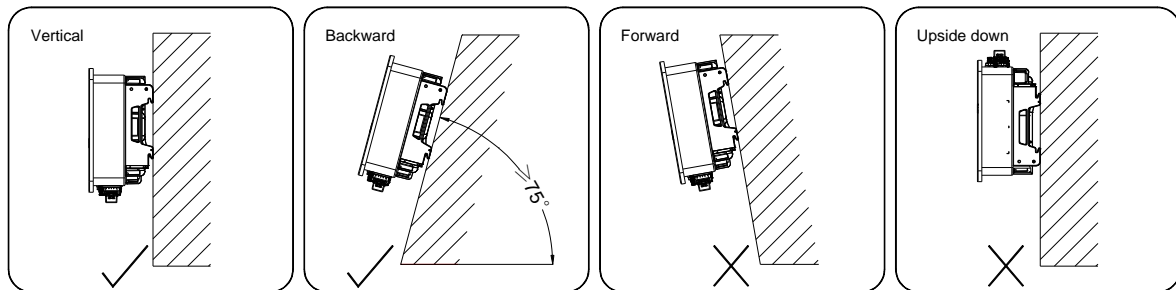

FIG 3-2 Installation angle

### 3.3 Installation Clearance Requirements

1) Reserve enough clearance around the inverter to ensure sufficient space for heat dissipation, shown as FIG 3-3. (Under the premise of ensuring installability, the gap between the left and right sides of the inverter can be reduced to 200mm, and it is recommended to be  $\geq 500$ mm.)

2) In case of multiple inverters, reserve specific clearance between the inverters. 3-4

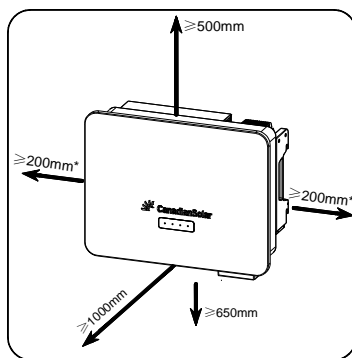

FIG 3-3 Single installation space

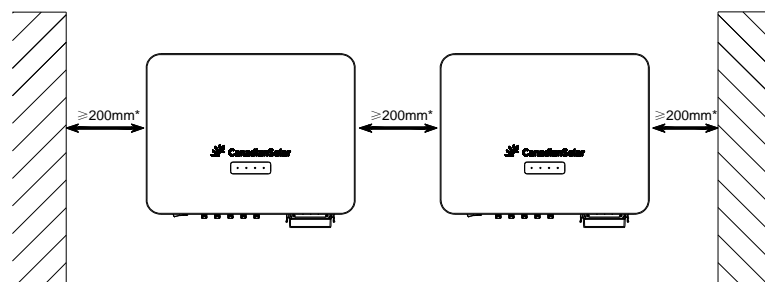

FIG 3-4 Multiple installation space

3) In case of back-to-back installation, reserve specific clearance between the two inverters.

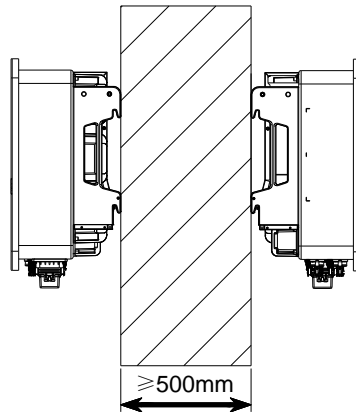

FIG 3-5 Back-to-back installation

### 3.4 Assembling the mounting-bracket

Dimensions of the assembled mounting-bracket are as follows.

Assemble the mounting-bracket by using the connecting bar.

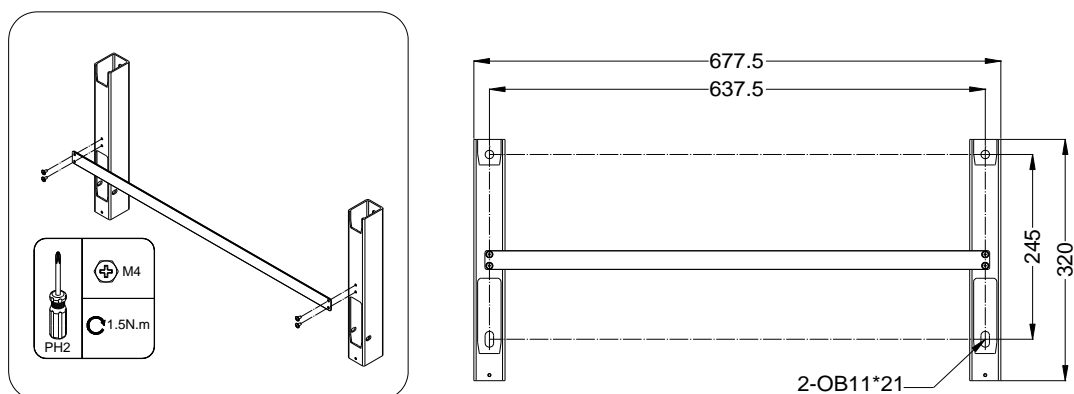

FIG 3-6 Assembly mounting bracket

#### 3.4.1 Standard C or U Steel Installation

Mounting Steps:

Step 1 Localize the hole positions in C or U-section steel to install mounting bracket.

Step 2 Secure the mounting bracket with M8 bolts and nuts.

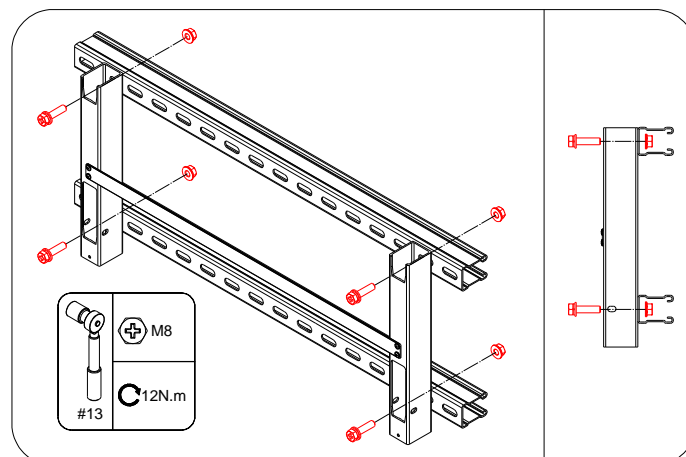

FIG 3-7 Locate the mounting hole

### 3.4.2 Steel Frame Installation

#### Mounting Steps:

Step 1: Level the assembled mounting-bracket by using a level, and mark the positions for drilling holes on the steel frame. Drill the holes by using a hammer drill. Recommended aperture:10mm.

Step 2: Secure the mounting-bracket with M8 bolts and nuts.

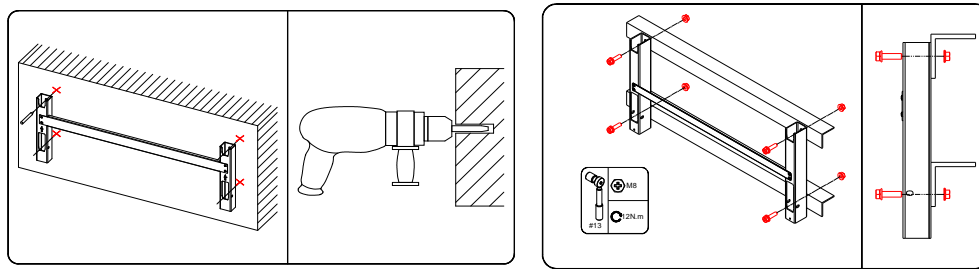

FIG 3-8 Install the wall bracket

### 3.4.3 Wall-Mounted Installation

M8 or M10 expansion bolts can be used to fix the wall bracket on the wall. (Note: No expansion bolt is supplied)

#### Mounting Steps

Step 1: Level the assembled mounting-bracket by using a level, and mark the positions for drilling holes on the installation site.

Step 2: Insert the expansion bolts into the holes and secure them with a rubber hammer. Fasten the nut with a wrench to expand the bolt. Remove the nut, spring washer, and flat washer, and store them properly.

Step 3: Fix the mounting-bracket with the expansion bolts.

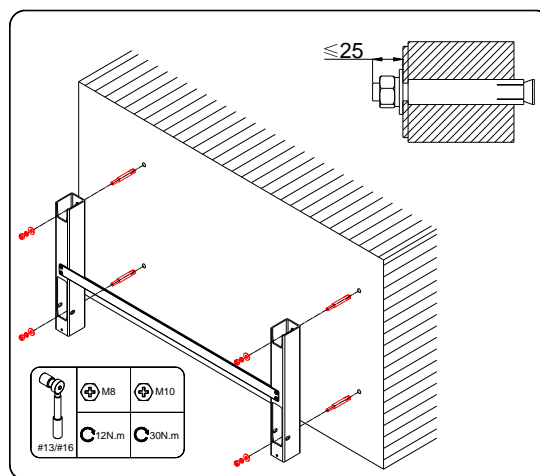

FIG 3-9 Install the wall bracket

## 3.5 Inverter Installation

Step 1: Take out the inverter from the packing carton.

Step 2: If the inverter is installed in a high position, hoisting the inverter is recommended (refer to manual "4.3.2 Hoisting Transport"). If not, skip performing this step.

Step 3: Hang the inverter to the mounting-bracket and ensure that the mounting ears perfectly engage with the mounting-bracket.

Step 4: Fix the inverter with screws M6x30 (Note: It is not locked or fixed here, and the screw can be locked to the end).

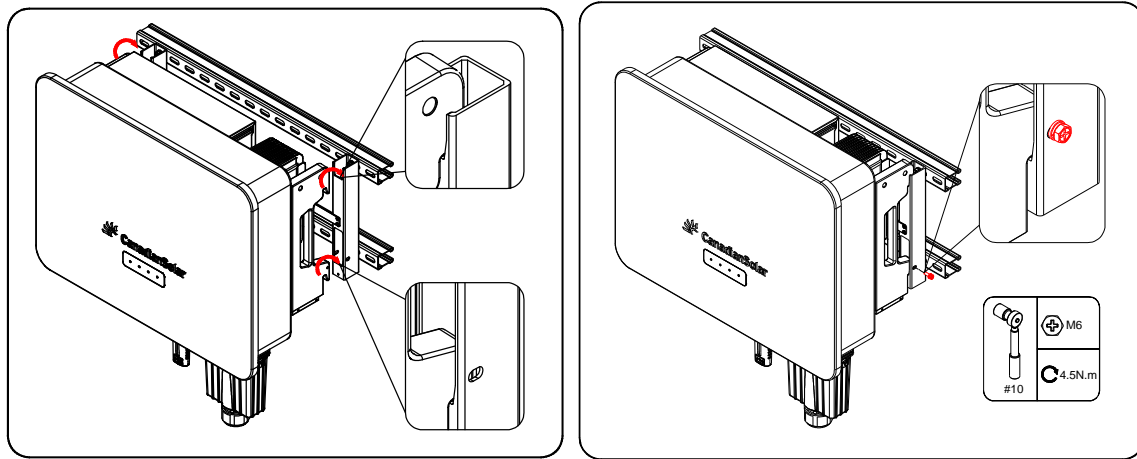

FIG 3-10 Install the inverter

## 4 Electrical Connection

### 4.1 Electrical Connection Overview

1) PV string; 2) Inverter; 3) AC distribution box/cabinet; 4) Utility grid; 5) Monitoring device

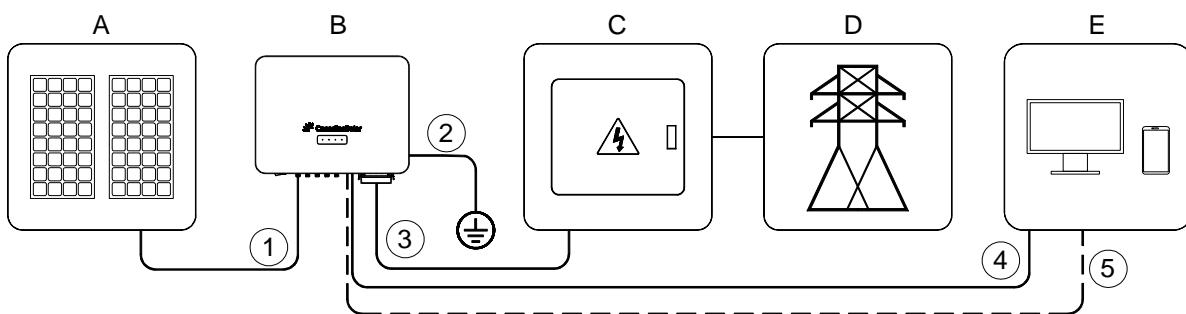

FIG 4-1 General electrical connection diagram

Table 4-1 Recommended Cables

No.	Cable Name	Cable Type	Conductor Cross-Sectional Area	Outer Diameter
1	DC cable	PV cable, complying with 1500V standard	4~6mm <sup>2</sup>	6~9mm
2	Additional Grounding cable	Outdoor single core copper conductor cable	The same as that of the PE wire in the AC cable	N/A
3	AC cable	Four/Five-core outdoor copper or aluminum cables* 【1】	L1/L2/L3/N (40kW) : 16~35 mm <sup>2</sup> L1/L2/L3/N (50-60kW) : 25~50 mm <sup>2</sup> PE wire: refer to "table 4-2 PE wire requirements"	22~38mm
4	Communication cable	Shielded twisted pair	0.2~1.5 mm <sup>2</sup>	4.0~5.5mm
5	Wireless communication	N/A	N/A	N/A

\* 【1】 A copper to aluminum adapter terminal is required when an aluminum cable is used.

Tbale 4-2 PE wire requirements

Phase wire cross section S	PE wire cross section	Note
$16 < S \leq 35 \text{ mm}^2$	16 mm <sup>2</sup>	The specifications are valid only when the phase wire and PE wire use the same material. If otherwise, ensure that the cross section of PE wire produces a conductance equivalent to that of the wire specified in the table.
$S > 35 \text{ mm}^2$	S/2	

## 4.2 Connecting the PE Cable

 <b>WARNING</b>	<p>Since the inverter is a transformerless inverter, neither the negative pole nor the positive pole of the PV string can be grounded. Otherwise, the inverter will not operate normally.</p> <p>Connect the additional grounding terminal to the protective grounding point before AC cable connection, PV cable connection, and communication cable connection.</p> <p>The ground connection of this additional grounding terminal cannot replace the connection of the PE terminal of the AC cable. Make sure thoes terminals are both grounded reliably.</p>
---	--

### 4.2.1 Additional Grounding Requirements

All non-current carrying metal parts and device enclosures in the PV power system should be grounded, for example, brackets of PV modules and inverter enclosure. When there is only one inverter in the PV system, connect the additional grounding cable to a nearby grounding point.

When there are multiple inverters in the PV system, connect grounding points of all inverters and the PV array frames to the equipotential cable (according to the onsite conditions) to implement an equipotential connection.

### 4.2.2 Connection Procedure

Step 1 Prepare an external ground cable according to the following figure: strip the cable -> crimp the terminal -> cover the heat shrinkable sleeve. Recommended terminal type: DT/OT.

Step 2 Remove the screw on the grounding terminal and fasten the cable with a wrench.

Step 3 Apply paint to the grounding terminal to ensure corrosion resistance.

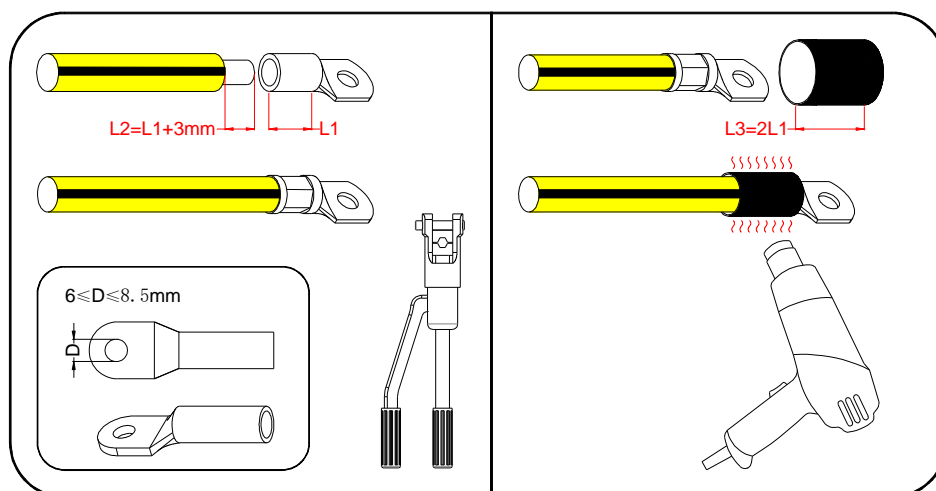



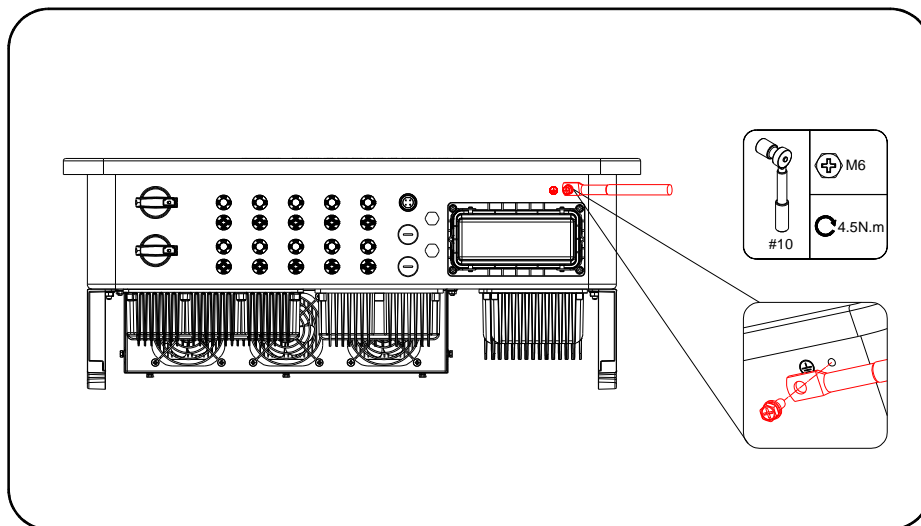

FIG 4-2 Install ground cables

### 4.3 Communication Cable Connection

This series of models provides standard wireless communication function and optional wired communication function.

#### 4.3.1 Data Logger Connection

Connect the Data Logger to the communication accessory port.

After successful connection, information such as power generation and running state of the inverter can be viewed via the APP on the phone.

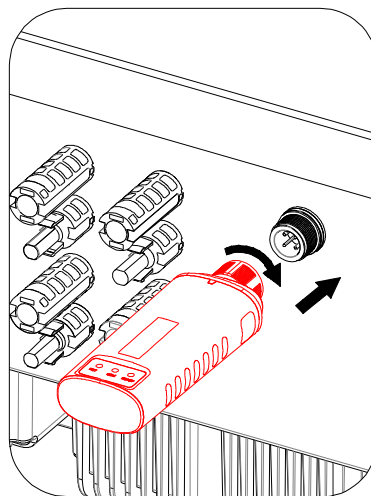

FIG 4-3 Data logger connection

### 4.4 AC Cable Connection

#### 4.4.1 AC Side Requirements

Before connecting the inverter to the grid, ensure the grid voltage and frequency comply with requirements, for which, refer to Specification. Otherwise, contact the electric power company for help.



Connect the inverter to the grid only after getting an approval from the local electric power company.

#### 4.4.2 Connection Procedure

Step 1: Disconnect the AC-side circuit breaker and prevent it from inadvertent reconnection.

Step 2: Open the wiring compartment, loosen the swivel nut of the AC waterproof connector, take out the multi-layer sealing ring and select a seal rings according to the cable outer diameter. Lead the cable through the swivel nut, seal rings, and wiring compartment successively.

Step 3: Strip the protection layer and insulation layer by specific length, as described in the figure below.

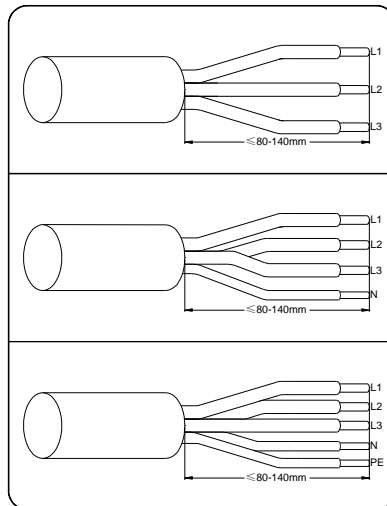

FIG 4-4 Strip the protection layer and insulation layer

Step 4: Make the cable and crimp OT/DT terminal.

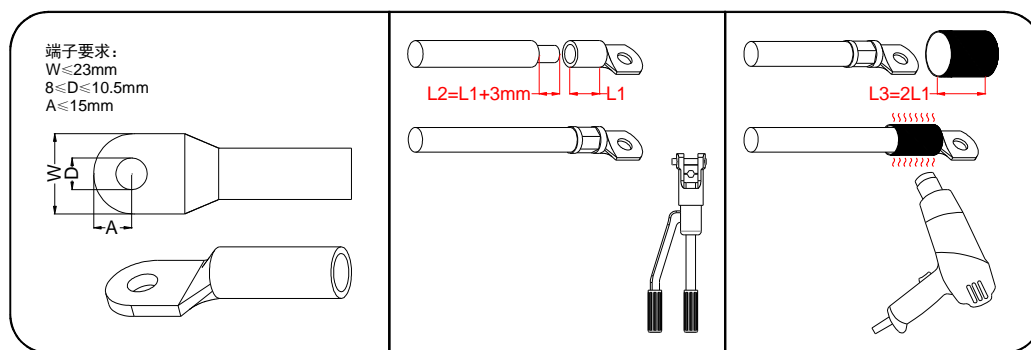

FIG 4-5 Make the cable

Step 5: Remove the protective box by pushing the clasp in the left and right directions. Take out the inter-pole insulation shield of the terminal block delivered with the machine and install it on the terminal block.

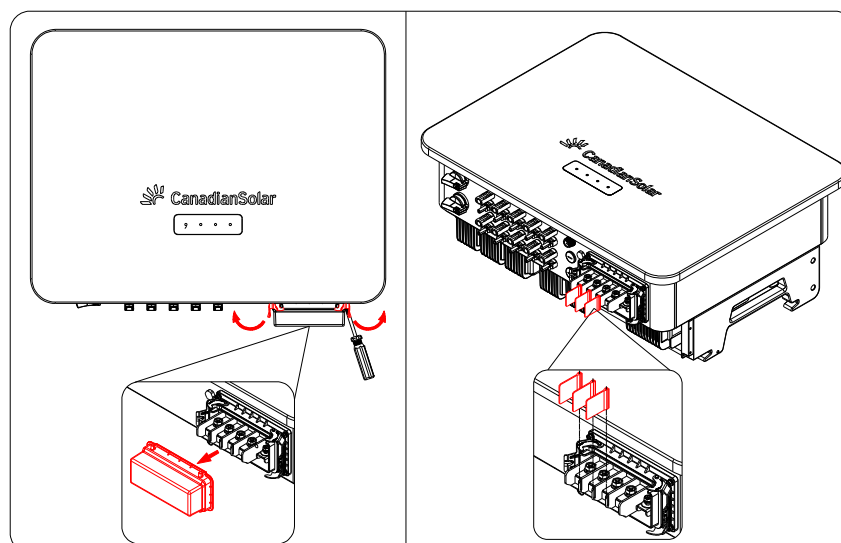

FIG 4-6 Remove the protective box and install the insulation shield between terminals

Step 6: Connect the AC cable with crimped terminals to the inverter AC terminal block.

Recommended locking torque: 8-10N.m

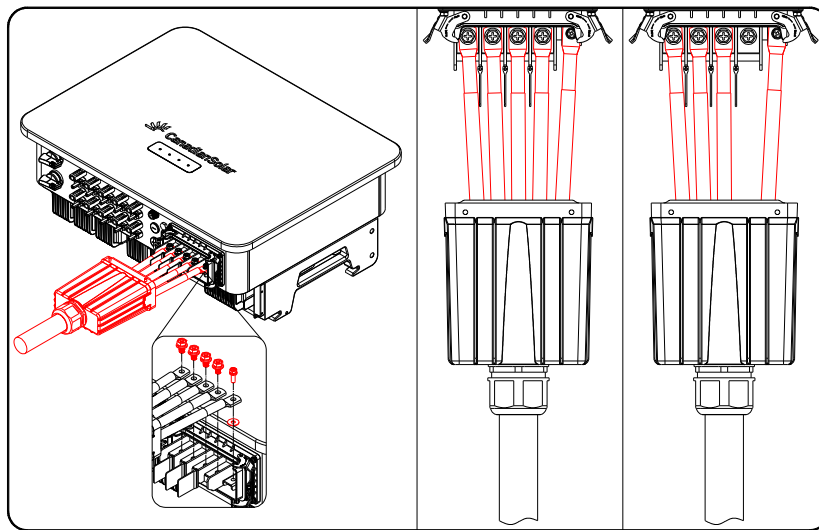

FIG 4-7 Connect AC cable

Step 7: Pull back the buckle to secure the wiring compartment.

Step 8: Gently pull the cable backwards to ensure firm connection, and fasten the swivel nut clockwise.

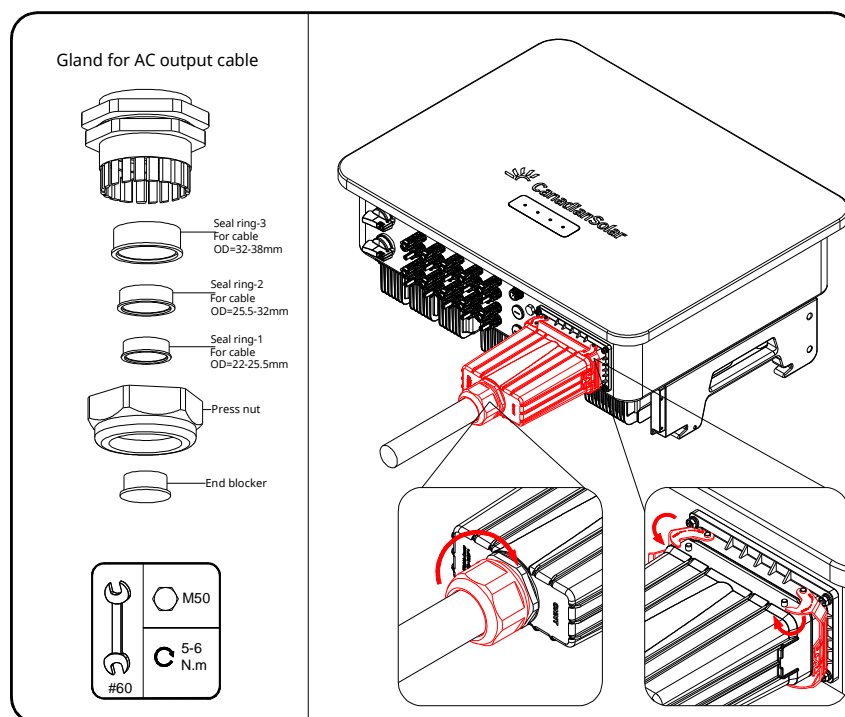





FIG 4-8 Recommended AC cable connection position.

Note: The gap between AC cable and waterproof gland must be blocked with fireproof mud to prevent water or moisture.

#### 4.5 DC Cable Connection

 <p><b>DANGER</b></p>	<p>Electric shock! The PV array will generate lethal high voltage once exposed to sunlight. Before performing electrical operations, ensure that all cables are uncharged. Do not turn on the AC circuit breaker before the inverter is electrically connected.</p>
 <p><b>CAUTION</b></p>	<p>Make sure the PV array is well insulated to ground before connecting it to the inverter.</p>

	<p>During the installation of PV strings and the solar inverter, the positive or negative terminals of PV strings may be short-circuited to ground if the power cable is not properly installed or routed. In this case, an AC or DC short circuit may occur and damage the solar inverter. The caused device is not covered under any warranty.</p>
 <b>NOTICE</b>	<p>There is a risk of inverter damage! The following requirements should be met.            Failure to do so will void guarantee and warranty claims.</p> <ul style="list-style-type: none"> <li>• Make sure the maximum voltage of each string is always less than 1100 V.</li> <li>• The inverter enters the standby state when the input voltage ranges between 1,000V and 1,100V. The inverter returns to the running state once the voltage returns to the MPPT operating voltage range, namely, 200 to 1,000V.</li> </ul> <p>Make sure the maximum short circuit current on the DC side is within the permissible range.</p> <ul style="list-style-type: none"> <li>• The polarities of electric connections are correct on the DC input side. The positive and negative terminals of a PV module connect to corresponding positive and negative DC input terminals of the solar inverter.</li> </ul>
 <b>CAUTION</b>	<p>Use the connectors delivered with the solar inverter. If the PV connectors are lost or damaged, purchase the connectors of the same model. The device damage caused by incompatible PV connectors is beyond the warranty scope.</p>

#### 4.5.1 Connection Procedure

Step 1: Strip the insulation from each DC cable by 7mm.

Step 2: Assemble the cable ends with the crimping pliers

Step 3: Lead the cable through cable gland, and insert into the insulator until it snaps into place.

Gently pull the cable backward to ensure firm connection. Tighten the cable gland and the insulator (torque 2.5 N.m to 3 N.m).

Step 4: Check for polarity correctness.

The inverter will not function properly if any PV polarity is reversed.

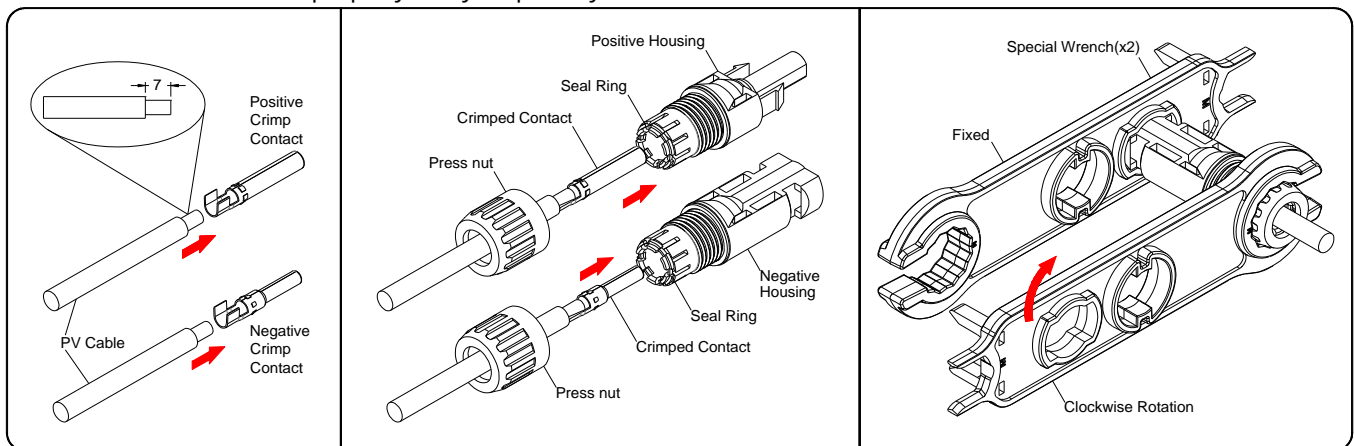

FIG 4-9 DC cable connection

#### 4.5.2 Installing the PV Connectors.

step 1: Rotate all the DC switches to "OFF" position.

step 2: Check the cable connection of the PV string for polarity correctness and ensure that the open circuit voltage in any case does not exceed the inverter input limit of 1,100V.

step 3: Connect the PV connectors to corresponding terminals until there is an audible click.

step 4: Follow the foregoing steps to connect PV connectors of other PV strings.

step 5: Seal the unused PV terminals with the terminal caps.

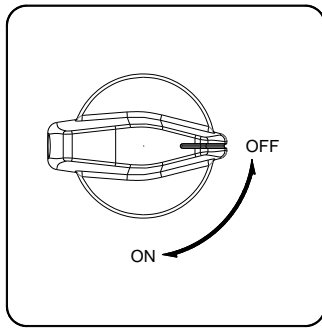

FIG 4-10 DC switch

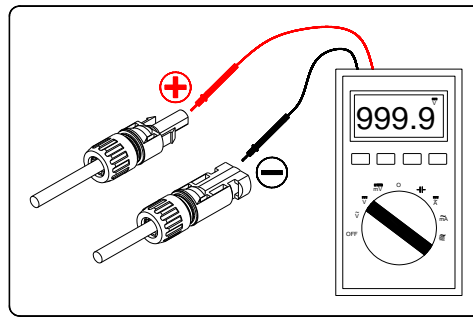

FIG 4-11 Check the polarity of PV string

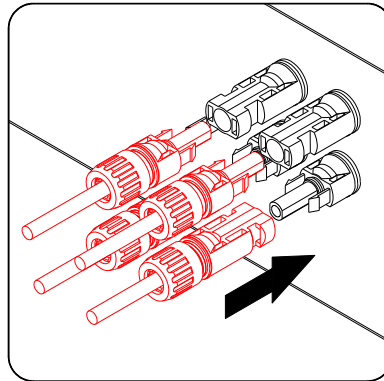

FIG 4-12 Connect the PV connectors to the inverter

## 5 Commissioning Inverter

### 5.1 Electrical Inspection

- 1) The inverter DC switch and external circuit breaker are disconnected
- 2) The inverter should be accessible for operation, maintenance and service.
- 3) Nothing is left on the top of the inverter.
- 4) The inverter is correctly connected to the external devices, and the cables are routed in a safe place or protected against mechanical damage.
- 5) The selection of the AC circuit breaker is in accordance with this manual and all applicable local standards.
- 6) All unused terminals at the bottom of the inverter are properly sealed.
- 7) Warning signs & labels are suitably affixed and durable.

### 5.2 Commissioning Procedure

If all of the items mentioned above meet the requirements, proceed as follows to start up the inverter for the first time.

Step 1: Rotate the DC switch of the inverter to "ON" position.

Step 2: Connect the AC switch (if applicable) between the inverter and the grid.

Step 3: Connect the DC switch (if applicable) between the inverter and the PV string.

Step 4: Set initial protection parameters via the CSI Cloud App. If the irradiation and grid conditions meet requirements, the inverter will normally operate.

Step 5: Observe the LED indicator to ensure that the inverter operates normally.

## 6 CSI CloudPro APP

### 6.1 APP Introduction

The CSI CloudPro APP can establish communication connection to the inverter via the Blue-tooth, thereby achieving near-end maintenance on the inverter. Users can use the App to view basic information, alarms and events, set parameters, etc.

## 6.2 Download and Install the App

Method 1: Scan the following QR Code to download and install the App according to the prompt information.



Method 2: Download and install the App through the following application stores:

- Google Play(Android)
- APP Store(iOS)

## 6.3 Use the Local Mode to Login the App

Notice: To use the local mode, the following conditions should be met:

- (1) The collector is connected to the inverter and powered on.
- (2) The distance between the mobile phone and the collector should be within 5m and there is no shelter.

Step 1: Open the CSI CloudPro APP.

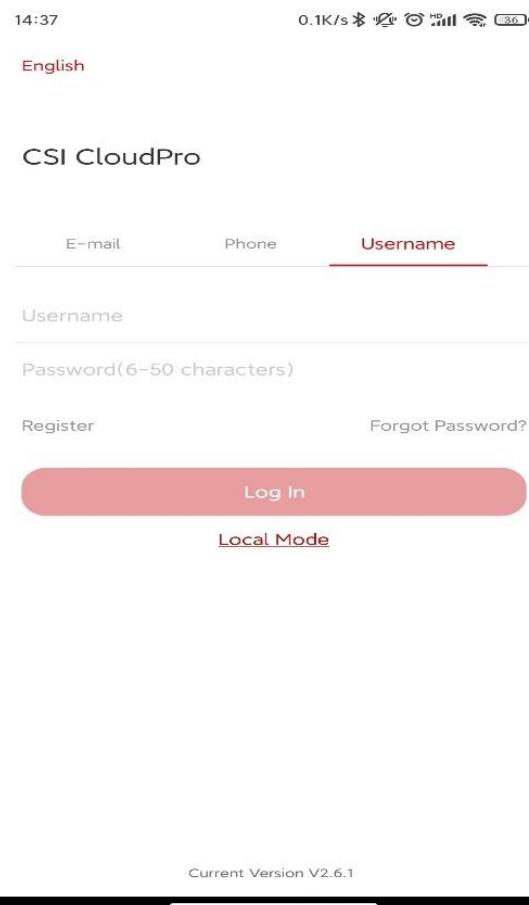

Step 2: Select "Local Mode", then scan logger SN. The mobile phone will connect to the collector automatically.

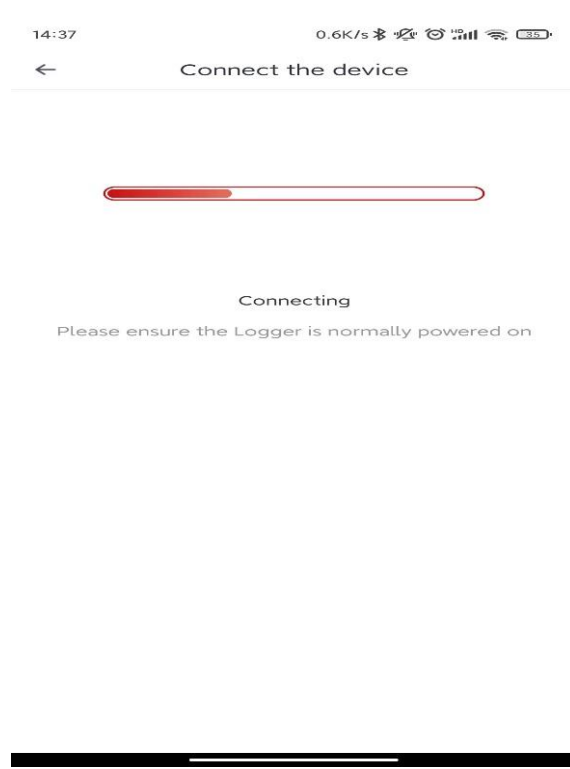

Step 3: After the connection succeeds, users can view the real-time operating data of the inverter.

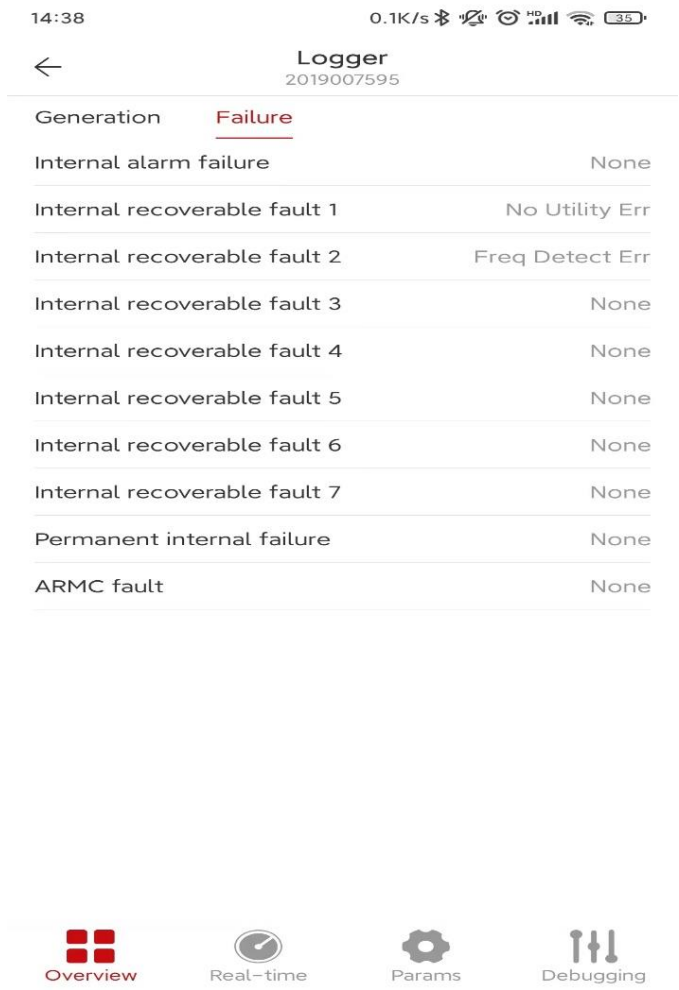
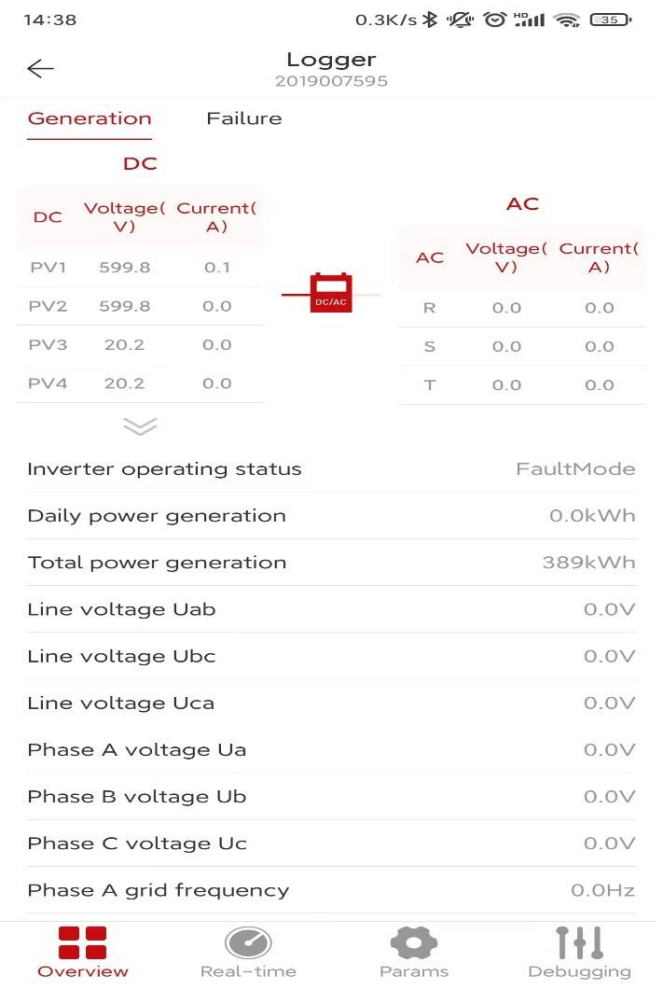

Step 4: Select "Params", enter the password 000000 and login the system. Then, users can view and modify parameters

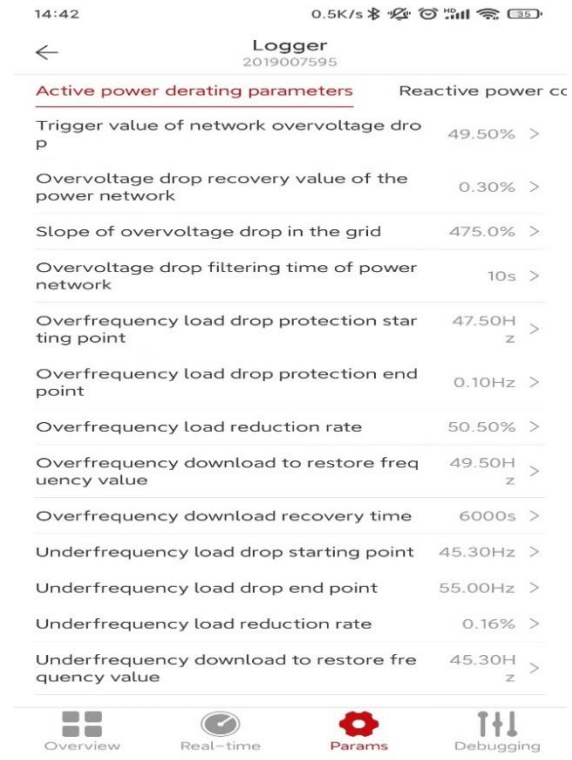
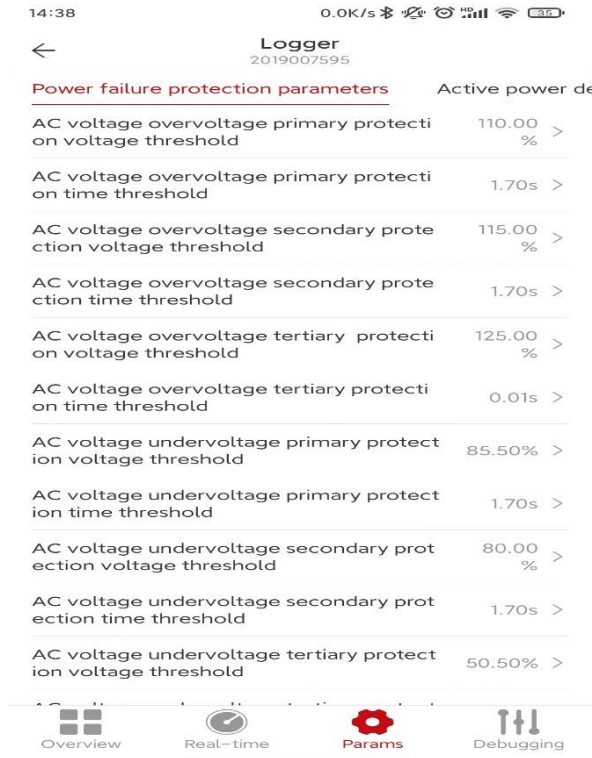

\*APP pictures are for reference only.

## 7 Obtaining User Manual

Please scan the QR code for more detailed information in user manual.

